

ASME Y14.1M-2012
[Revision of ASME Y14.1M-2005 (R2010)]

Metric Drawing Sheet Size and Format

**Engineering Drawing and Related
Documentation Practices**

AN AMERICAN NATIONAL STANDARD



**The American Society of
Mechanical Engineers**

ADOPTION NOTICE

ASME Y14.1M, "Metric Drawing Sheet Size and Format," was adopted on 10 March 1995 for use by the Department of Defense (DoD). Proposed changes by DoD activities must be submitted to the DoD Adopting Activity: Commander, U.S. ARDEC, ATTN: RDAR-QES-E, Picatinny Arsenal, NJ 07806-5000 or emailed to usarmy.picatinny.ardec.list.ardec-stdzn-branch@mail.mil. Copies of this document may be purchased from the American Society of Mechanical Engineers, Two Park Avenue, New York, New York, United States, 10016. <http://www.asme.org>.

Custodians:

Army — AR
Navy — SA
Air Force — 16
DLA — DH

Adopting Activity:

Army — AR
(Project DRPR-2013-001)

Review Activities:

Army — AV, CR, MI, PT, TE, TM
Navy — AS, CG, CH, MC, NP
Air Force — 04, 13, 99
DLA — IS
OSD — SE
Other — CM, MP, DC2, NS

NOTE: The activities listed above were interested in this document as of the date of this document. Since organizations and responsibilities can change, you should verify the currency of the information above using the ASSIST Online database at <https://assist.dla.mil>.

AMSC N/A

AREA DRPR

DISTRIBUTION STATEMENT A. Approved for public release; distribution is unlimited.

ASME Y14.1M-2012

[Revision of ASME Y14.1M-2005 (R2010)]

Metric Drawing Sheet Size and Format

**Engineering Drawing and Related
Documentation Practices**

AN AMERICAN NATIONAL STANDARD



**The American Society of
Mechanical Engineers**

Two Park Avenue • New York, NY • 10016 USA

Date of Issuance: March 15, 2013

This Standard will be revised when the Society approves the issuance of a new edition.

Errata to codes and standards may be posted on the ASME Web site under the Committee Pages to provide corrections to incorrectly published items, or to correct typographical or grammatical errors in codes and standards. Such errata shall be used on the date posted.

The Committee Pages can be found at <http://cstools.asme.org/>. There is an option available to automatically receive an e-mail notification when errata are posted to a particular code or standard. This option can be found on the appropriate Committee Page after selecting “Errata” in the “Publication Information” section.

ASME is the registered trademark of The American Society of Mechanical Engineers.

This code or standard was developed under procedures accredited as meeting the criteria for American National Standards. The Standards Committee that approved the code or standard was balanced to assure that individuals from competent and concerned interests have had an opportunity to participate. The proposed code or standard was made available for public review and comment that provides an opportunity for additional public input from industry, academia, regulatory agencies, and the public-at-large.

ASME does not “approve,” “rate,” or “endorse” any item, construction, proprietary device, or activity.

ASME does not take any position with respect to the validity of any patent rights asserted in connection with any items mentioned in this document, and does not undertake to insure anyone utilizing a standard against liability for infringement of any applicable letters patent, nor assumes any such liability. Users of a code or standard are expressly advised that determination of the validity of any such patent rights, and the risk of infringement of such rights, is entirely their own responsibility.

Participation by federal agency representative(s) or person(s) affiliated with industry is not to be interpreted as government or industry endorsement of this code or standard.

ASME accepts responsibility for only those interpretations of this document issued in accordance with the established ASME procedures and policies, which precludes the issuance of interpretations by individuals.

No part of this document may be reproduced in any form,
in an electronic retrieval system or otherwise,
without the prior written permission of the publisher.

The American Society of Mechanical Engineers
Two Park Avenue, New York, NY 10016-5990

Copyright © 2013 by
THE AMERICAN SOCIETY OF MECHANICAL ENGINEERS
All rights reserved
Printed in U.S.A.

CONTENTS

Foreword	iv
Committee Roster	v
Correspondence With the Y14 Committee	vi
1 General	1
2 References	2
3 Terms and Definitions	2
4 Drawing Sheet Sizes	4
5 Formats	4
6 Title Blocks	5
7 Revision History Block	5
8 Revision Status of Sheets Block	6
9 Associated Lists	6
10 Additional Data Blocks	6
11 Additional Drawing Number Blocks	6
Figures	
4-1 Basic Sheet Size Formats, A0 Through A4 Sizes	7
4-2 Elongated Sheet Size Formats, A1.0, A2.1, A2.0, A3.2, A3.1, and A3.0 Sizes	8
4-3 System Size Overview	9
5-1 Title Block for A2, A3, and A4 Sizes	9
5-2 Title Block for A0 and A1 Sizes	10
5-3 Continuation Sheet Title Block for A2, A3, and A4 Sizes	10
5-4 Continuation Sheet Title Block for A0 and A1 Sizes	11
5-5 Microfilm Arrowheads	11
5-6 Microfilm Identification Block	12
7-1 Revision History Block	12
8-1 Revision of Status of Sheets Block	12
10-1 Tolerance and Projection Blocks	13
10-2 Application Block	13
11-1 Margin Drawing Number Block	14
Tables	
4-1 Basic Sheet Sizes	15
4-2 Elongated Sheet Sizes	15

FOREWORD

This Standard establishes a series of recommended metric drawing sizes and the basic format for engineering drawings. It provides a basis for uniformity in engineering drawing size and format that industry and government can utilize. It is not the intent of this Standard to prevent individual organizations from designing specific formats that meet their individual needs, but rather to provide common engineering delineation standards to aid the interchange of drawings between industry, government, and other users.

This Standard is a revision of ASME Y14.1M-2005, Metric Drawing Sheet Size and Format. It has been prepared in alignment with the United States Omnibus Trade and Competitiveness Act of 1988, Section 5164, Metric Usage.

This Standard utilizes International Standard ISO 5457 as the basis for recommended metric engineering drawing size and format.

This Standard has been developed to lend itself with the least amount of variation from the presently recognized International Standard, and has been structured to support the United States Department of Defense (DoD) metrication policy and objectives.

Work on the revision of this Standard began in October 2010 in Tucson, Arizona by the members of Subcommittee 1.

The following is a summary of the significant changes that were incorporated into this revision:

- (a) Added ASME Y14 Series Conventions section.
- (b) Revised various definitions to match those listed in ASME Y14.100.
- (c) Added definition for *field of drawing* and updated Figs. 4-1 and 4-2.
- (d) Clarified para. 4.2 (formerly para. 2.2) regarding how the lengths of elongated sheets are determined.
- (e) Expanded zoning practices to address continuous and repetitive zoning methods.
- (f) Microfilming practices are now listed as optional.
- (g) Introduced (design activity identification) DAI, replacing CAGE Code.
- (h) Addressed revision status of sheet block for multiple-sheet drawings with maintained at the same revision level.
- (i) Made the location of the angle of projection block optional (within or adjacent to the title block).
- (j) Changed reference to ASME Y14.5 in Fig. 10-1.

Where this Standard is specified as a requirement in a document, its defined requirements are assumed to be consistent with the needs of the user. Therefore, each user provides appropriate interpretations, as the need arises, consistent with the environment in which it is applied.

The successful revision of this Standard is attributed to the subcommittee members and their respective companies, and the Department and Agencies of the U.S. Government.

Suggestions for the improvement of this Standard are welcome. They should be sent to The American Society of Mechanical Engineers, Attn: Secretary, Y14 Standards Committee, Two Park Avenue, New York, NY 10016-5990.

This revision was approved by American National Standard Institute (ANSI) as an American National Standard on December 19, 2012.

ASME Y14 Committee Engineering Drawing and Related Documentation Practices

(The following is the roster of the Committee at the time of approval of this Standard.)

STANDARDS COMMITTEE OFFICERS

F. Bakos, Jr., *Chair*
W. A. Kaba, *Vice Chair*
F. Constantino, *Secretary*

STANDARDS COMMITTEE PERSONNEL

A. R. Anderson, Dimensional Control Systems, Inc.
F. Bakos, Jr., Consultant
J. V. Burleigh, Consultant
F. Constantino, The American Society of Mechanical Engineers
D. E. Day, TEC_EASE, Inc.
K. Dobert, Siemens
C. W. Ferguson, WM Education Services
B. A. Harding, Purdue University
D. H. Honsinger, Consultant
W. A. Kaba, Sprint AeroSystems, Inc.
A. Krulikowski, Effective Training
E. McCarthy, Ratheon Co.
P. J. McCuiston, Ohio University
J. D. Meadows, James D. Meadows & Associates, Inc.
H. W. Oakes, United States Air Force (Peerless Technologies Corp.)
N. H. Smith, Sprint AeroSystems, Inc.
M. J. Stahl, Caterpillar, Inc.
R. G. Wilhelm, University of North Carolina
B. A. Wilson, The Boeing Co.

SUBCOMMITTEE 1 — DRAWING SHEET SIZE AND FORMAT

J. B. Hoskins, *Chair*, The Boeing Co.
J. V. Burleigh, Consultant
B. A. Harding, Purdue University
G. M. Nelson, Consultant
R. H. Settle, Naval Surface Warfare Center, Dahlgren Division
N. Stern, United States Army
M. W. Woodworth, *Retired*, U.S. Department of the Air Force

CORRESPONDENCE WITH THE Y14 COMMITTEE

General. ASME Standards are developed and maintained with the intent to represent the consensus of concerned interests. As such, users of this Standard may interact with the Committee by requesting interpretations, proposing revisions, and attending Committee meetings. Correspondence should be addressed to:

Secretary, Y14 Standards Committee
The American Society of Mechanical Engineers
Two Park Avenue
New York, NY 10016-5990
<http://go.asme.org/inquiry>

Proposing Revisions. Revisions are made periodically to the Standard to incorporate changes that appear necessary or desirable, as demonstrated by the experience gained from the application of the Standard. Approved revisions will be published periodically.

The Committee welcomes proposals for revisions to this Standard. Such proposals should be as specific as possible, citing the paragraph number(s), the proposed wording, and a detailed description of the reasons for the proposal, including any pertinent documentation.

Attending Committee Meetings. The Y14 Standards Committee regularly holds meetings that are open to the public. Persons wishing to attend any meeting should contact the Secretary of the Y14 Standards Committee.

ENGINEERING DRAWING AND RELATED DOCUMENTATION PRACTICES

METRIC DRAWING SHEET SIZE AND FORMAT

1 GENERAL

1.1 Scope

This Standard defines metric sheet sizes and formats for engineering drawings. Decimal inch sheet sizes and format are defined in ASME Y14.1. For engineering drawing preparation and practices, see ASME Y14.100.

1.2 Purpose

Standardization of drawing sheet sizes and the uniform location of format features on drawing forms provides definite advantages in readability, handling, filing, and reproduction. In using drawing sheets made by other organizations, an advantage is gained when like items of information are in the same location on all drawing sheets, and when uniformity of form and language is applied in making information entries. Revision information and dates are of particular importance to users of drawings and should be located and expressed uniformly on all engineering drawings.

The widespread use and exchange of reduced-size copies of drawing sheets both within and between organizations emphasizes the importance of standardization of drawing sheet size and format.

1.3 ASME Y14 Series Conventions

The following conventions are guidance used in this and other ASME Y14 series standards.

1.3.1 Mandatory, Nonmandatory, Guidance, and Optional Words

(a) The word “shall” establishes a mandatory requirement.

(b) The word “will” establishes an intended, mandatory requirement.

(c) The words “should” and “may” establish a non-mandatory practice.

(d) The words “typical,” “example,” “for reference,” or the Latin abbreviation “e.g.” indicate suggestions given for guidance only.

(e) When the text of this Standard has an “or” statement, it indicates that there are two or more options on how to comply with the stated requirement.

1.3.2 Cross-Reference of Standards. Cross-reference of standards in text with or without a date following the standard identity is interpreted as follows:

(a) Reference to other ASME Y14 series standards in the text without a date following the standard identity indicates the issue of the standard as identified in the Reference section shall be used to meet the requirement.

(b) Reference to other ASME Y14 series standards in the text with a date following the standard identity indicates that only that issue of the standard shall be used to meet the requirement.

1.3.3 Invocation of Referenced Standards. The following examples define the invocation of a standard when specified in the References section and referenced in the text of this Standard:

(a) When the text states “dimensioning and tolerancing shall be in accordance with ASME Y14.5-2009,” with no limitations to a specific subject or area of the Standard, the entire text of ASME Y14.5-2009 is invoked.

(b) When the text states “assign part or identifying numbers in accordance with ASME Y14.100-20XX,” only the paragraph requirements on part or identifying number assignment in ASME Y14.100-20XX are invoked.

(c) When the text states “for gaging principles, see ASME Y14.43,” the text provides a cross-reference of where to find guidance for dimensioning and tolerancing for gages and fixtures, and no portion of ASME Y14.43 is invoked.

1.3.4 Parentheses Following a Definition. When a definition is followed by a standard referenced in parentheses, the standard referenced in parentheses is the controlling standard for the definition.

1.3.5 Notes. Notes depicted in this Standard in ALL UPPERCASE letters are intended to reflect actual drawing entries. Notes depicted in initial Uppercase or lowercase letters are to be considered supporting data to the contents of this Standard and are not intended for literal entry on drawings. A statement requiring the addition of a note with the qualifier “such as” is a requirement to add a note, and the content of the text is allowed to vary to suit the application.

1.3.6 Acronyms and Abbreviations. Acronyms and abbreviations are spelled out the first time used in this

Standard, followed by the acronym or abbreviation in parentheses. The acronym or abbreviation is used thereafter throughout the text.

1.3.7 Units. All dimensions used in this Standard are in millimeters.

1.3.8 Figures. The figures in this Standard are intended only as illustrations to aid the user in understanding the practices described in the text. In some cases, figures show a level of detail as needed for emphasis. In other cases, figures are incomplete by intent so as to illustrate a concept or facet thereof. The absence of figure(s) has no bearing on the applicability of the stated requirements or practice. To assist the user of this Standard, a listing of the paragraph(s) that refer to an illustration appears in the lower right-hand corner of each figure. This listing may not be all-inclusive. The absence of a listing is not a reason to assume inapplicability. When the letter “h” is used in figures for letter heights or for symbol proportions, select the applicable letter height in accordance with ASME Y14.2.

1.3.9 Precedence of Standards. The following are Y14 standards that are basic engineering drawing standards:

ASME Y14.1	Drawing Sheet Size and Format
ASME Y14.1M	Metric Drawing Sheet Size and Format
ASME Y14.2	Line Conventions and Lettering
ASME Y14.3	Orthographic and Pictorial Views
ASME Y14.5	Dimensioning and Tolerancing
ASME Y14.24	Types and Applications of Engineering Drawings
ASME Y14.34	Associated Lists
ASME Y14.35M	Drawing Revisions
ASME Y14.36	Surface Texture Symbols
ASME Y14.38	Abbreviations
ASME Y14.41	Digital Product Definition Data Practices
ASME Y14.100	Engineering Drawing Practices

All other ASME Y14 standards are considered specialty types of standards and contain additional requirements or make exceptions to the basic standards as required to support a process or type of drawing.

1.3.10 Unless Otherwise Specified (UOS). The phrase “unless otherwise specified” or UOS is used to indicate a default requirement. The phrase is used when the default is a generally applied requirement and the exception can be clarified by providing a reference to another document or requirement.

2 REFERENCES

The following revisions of American National Standards form a part of this Standard to the extent specified herein. A more recent revision may be used provided there is no conflict with the text of this

Standard. In the event of a conflict between the text of this Standard and the references cited herein, the text of this Standard shall take precedence.

ASME Y14.1-2012, Decimal Inch Drawing Sheet Size and Format
 ASME Y14.2-2008, Line Conventions and Lettering
 ASME Y14.3-2003, Multiview and Sectional View Drawings
 ASME Y14.5-2009, Dimensioning and Tolerancing
 ASME Y14.34-2008, Associated Lists
 ASME Y14.35M-1997, Revision of Engineering Drawings and Associated Documents
 ASME Y14.100-2004, Engineering Drawing Practices
 Publisher: The American Society of Mechanical Engineers (ASME), Two Park Avenue, New York, NY 10016-5990; Order Department: 22 Law Drive, P.O. Box 2900, Fairfield, NJ 07007-2900

3 TERMS AND DEFINITIONS

3.1 Assembly

assembly: a number of parts, or any combination thereof, joined together to perform a specific function, and subject to disassembly without degradation of any of the parts (e.g., power shovel-front, fan assembly, audio-frequency amplifier) (ASME Y14.100).

NOTE: The distinction between an assembly and a subassembly is determined by individual application. An assembly in one instance may be a subassembly in another instance where it forms a portion of a higher assembly.

3.2 Associated List

associated list: a tabulation of engineering information pertaining to an item depicted on an engineering drawing or by a set of drawings (e.g., parts list, data list, index list, wire list, and application list) (ASME Y14.34).

3.3 Commercial and Government Entity (CAGE) Code

Commercial and Government Entity (CAGE) Code: a five-character code that provides a unique activity identifier that is used by the government for activity identification. This method of activity identification has also been widely adopted by industry. (CAGE Codes are listed in Cataloging Handbook H4/H8) (ASME Y14.100).

3.4 Contract

contract: a mutually binding legal relationship obligating the seller to furnish the supplies or services, including construction, and the buyer to pay for them. It includes all types of commitments that obligate the procuring activity to an expenditure of appropriated funds and that, except as otherwise authorized, are in writing. In addition to bilateral instruments, contracts include, but are not limited to, awards and notices of awards; job orders or task letter issued under basic ordering agreements; letter contracts; orders, such as purchase

orders, under which the contract becomes effective by written acceptance or performance; and bilateral contract modifications (ASME Y14.100).

3.5 Contractor

contractor: an individual, partnership, company, corporation, association, or other service having a contract for the design, development, manufacture, maintenance, modification, or supply of items under the terms of a contract (ASME Y14.100).

3.6 Copy

copy: any reproduction or duplication, in any media, of an original (ASME Y14.100).

3.7 Design Activity

design activity: an organization that has, or has had, responsibility for the design of an item (ASME Y14.100).

3.7.1 Current Design Activity

current design activity: the design activity currently responsible for the design of an item. This may be the original design activity or a design activity to which the design responsibility has been transferred.

3.7.2 Original Design Activity

original design activity: the design activity originally responsible for the design and identification of an item whose drawing number and activity identification is shown in the title block of the drawings and associated documents.

3.8 Design Activity Identification (DAI)

design activity identification (DAI): the application of a unique identifier that distinguishes an activity or organization from another activity or organization. Examples of activity identification include activity name, activity name and address, or CAGE Code (ASME Y14.100).

3.9 Digital Data

digital data: data stored on a computer system that employs a display on which the user and the computer interact to create or alter entities for the production of layouts, drawings, numerical control tapes, or other engineering data (ASME Y14.100).

3.10 Document

document: a term applicable to the specifications; drawings; lists; standards; pamphlets; reports; and printed, typewritten, or otherwise created information, relating to the design, procurement, manufacture, testing, or acceptance inspection of items or services (ASME Y14.100).

3.11 Drawing

drawing: an engineering document or data set that discloses directly or by reference, by means of graphic or

textual presentations, or combinations of both, the physical or functional requirements of an item (ASME Y14.100).

3.12 Drawing Format

drawing format: the arrangement and organization of information within a drawing. This includes such features as the size and arrangement of blocks, notes, lists, revision information, and use of optional or supplemental blocks (ASME Y14.100).

3.13 Engineering Data

engineering data: engineering documents such as drawings, associated lists, accompanying documents, specifications, standards, or other information prepared or used by a design activity and relating to the design, manufacture, procurement, testing, or inspection of items (ASME Y14.100).

3.14 Field of Drawing

field of drawing: the area of the drawing that contains the product definition of an item (ASME Y14.100).

3.15 Item

item: a nonspecific term used to denote any unit or product, including materials, parts, assemblies, equipment, accessories, and computer software (ASME Y14.100).

3.16 Original

original: the current design activity's reproducible drawing or data set on which is kept the revision record recognized as official (ASME Y14.100).

3.17 Part

part: one item, or two or more items joined together, that is not normally subject to disassembly without destruction or impairment of designed use (e.g., transistor, composition resistor, screw, transformer, and gear) (ASME Y14.100).

3.18 Procuring Activity

procuring activity: the customer (ASME Y14.100).

3.19 Referenced Documents

referenced documents: design activity standards, drawings, specifications, or other documents referenced on drawings or lists (ASME Y14.100).

3.20 Standard

standard: a document that establishes technical criteria, methods, processes, and practices (ASME Y14.100).

3.20.1 Company Standard

company standard: a document produced by a company that establishes engineering and technical limitations

and applications for items, materials, processes, methods, designs, and engineering practices unique to that company.

3.21 Standardization Document

standardization document: a document developed for the purpose of standardizing items, materials, processes, or procedures (ASME Y14.100).

4 DRAWING SHEET SIZES

Drawing sheet size designations are listed in Tables 4-1 and 4-2 and graphically shown in Figs. 4-1 and 4-2. The sizes shown are the overall size of the sheets excluding protective or binding margins. See para. 4.1. Rounded corners may be used on all drawing sizes.

4.1 Margins

4.1.1 Format Margins. The format margin sizes shown in applicable figures are the minimum required.

NOTE: Additional Design Activity nonproduct definition data may be added within the drawing format margins.

4.1.2 Protective Margins. For elongated drawing sizes, additional lengths of vertical and horizontal margins are permissible. See Fig. 4-2.

4.1.3 Binding Margins. The margins of basic drawing sizes (format margins) may be increased when the document is to be bound in a book form. Both margins may be increased when the document is to be printed back to back. However, except for the binding margins, all other format, content, and actual sheet size requirements shall conform to this Standard.

4.2 Lengths of Elongated Drawing Sheet Sizes

Elongated sheet sizes are formed by combination of the dimensions of the width of an A-size sheet. For example, size A0 width equals size A1 length. This continues through size A3. The structure of the size system is shown in Fig. 4-3. Elongated A4 sheet sizes do not exist because they are equivalent to size A3.

4.2.1 Microfilm Compatibility. The minimum and maximum lengths shown for elongated drawing sizes are compatible with microfilm frame-size requirements. See Fig. 4-2.

4.3 Computer-Generated Drawings

When copies of computer-generated drawings are produced, sheet sizes may be increased to compensate for output device requirements, providing the copies can be trimmed to the sheet sizes specified in this Standard. However, the drawing format and content shall conform to the requirements of this Standard. The continuous lines and widths of lines shown in this Standard to form the various features (that is, the required blocks, columns, and margins) do not have to be used. However,

the format sizes and the relative positions of the data headings and data contents shall conform to the requirements of this Standard. The data headings and contents created by data processing systems shall be legible when reproduced.

5 FORMATS

5.1 Basic

Basic formats include the title block from Figs. 5-1 and 5-2, and shall be used for sheet one, and may be used for all sheets of a multiple-sheet drawing. The basic formats are defined in Figs. 4-1 and 4-2.

5.2 Continuation Sheets

Continuation sheets are used for second and subsequent sheets of a multiple-sheet drawing. See para. 6.3 for minimum title block information requirements. For continuation sheet title blocks, see Figs. 5-3 and 5-4. As an option, title blocks shown in Figs. 5-1 and 5-2 may be used. All sheets of a multiple-sheet drawing should be the same size.

5.3 Blocks

The sizes of blocks specified herein are minimum. For block content, see para. 6.2. Additional blocks may be added.

5.4 Lettering

The size and style of lettering printed on drawing formats shall be in accordance with ASME Y14.2.

5.5 Zoning

5.5.1 Zone Identification. Formats, except A4, shall include zones for reference purposes. Zones are indicated by alphabetical and numerical entries in format margins and by subdivisions or multiples thereof as indicated in Figs. 4-1 and 4-2. Size A4 may also be zoned.

5.5.2 Zoning Methods. There are two methods of numerical zoning on multiple-sheet drawings, repetitive and continuous. The repetitive method (preferred) is to begin each drawing sheet with zone number one. The repetitive method requires that zone references throughout all drawing sheets include the sheet number. When the repetitive method is not used, the continuous method shall be used throughout all drawing sheets starting with zone number one on sheet one, continuing each new sheet with the next higher zone number than the last number used on the previous sheet. Do not mix repetitive and continuous methods on the same drawing.

5.6 Lines

Width of lines shall be in accordance with ASME Y14.2. When contrasting line widths are desired, the following guidelines may be used:

(a) thick

- (1) borderline
- (2) outline of principal blocks
- (3) main division of blocks
- (4) segment match lines
- (b) thin
 - (1) division of parts list and revision history blocks
 - (2) minor subdivisions of the title block and supplementary blocks
 - (3) zone markers

5.7 Microfilm Alignment — Optional

5.7.1 Alignment Arrowheads. When used, arrowheads are placed in the format margins of drawings to facilitate the alignment of drawings for microfilming as illustrated in Figs. 4-1 and 4-2. Microfilm arrows shall be centered within the microfilm segment. See Fig. 5-5 for size and style.

5.7.2 Segment Match Lines. When used, segment match lines are shown on elongated drawing sizes for multiple-segment microfilming to facilitate matching after reproduction from the microfilm. They are placed inside the field of drawing adjoining the format margin as shown in Figs. 4-2 and 5-6.

6 TITLE BLOCKS

6.1 Location

The title block shall be located in the lower right corner of the format. See Figs. 4-1 and 4-2.

6.2 Contents

Certain information common to all drawings is shown in the title block. See Figs. 5-1, 5-2, 5-3, and 5-4 for block letter references given below.

- Block A The name or name and address of the company or original design activity whose drawing number appears in the drawing number block. On continuation sheets, this block is required in the absence of a design activity identification (DAI).
- Block B Drawing title.
- Block C Drawing number.
- Block D Sheet revision block. This block may be omitted when a revision history block is included on the sheet.
- Block E This block contains information in sub-blocks, such as names and dates, relative to the preparation and approval of the drawing. The sub-block titles, such as DRAFTER, CHECKER, ENGINEER, etc., shall be identified appropriately. When applicable, the contract number shall be included within this block.

Block F Approval by the design activity when different from the source preparing the drawing. This may be necessary when a contractor-subcontractor condition exists; otherwise this block may be absorbed into block E, or it may be used for other purposes.

Block G Approval by an activity other than those described for blocks E and F. Where not required, this block may be absorbed into block E or it may be used for other purposes.

Block H Predominant scale of the drawing sheet. Enter "NONE" when no scale is used. Each sheet may have a different predominant scale.

Block I Design activity identification (DAI). When required for identification of the original design activity whose drawing number is used. For the commercial sector where there is no requirement for the DAI, the DAI block may be left blank or eliminated.

Block J Drawing size designation. See Tables 4-1 and 4-2.

Block K Actual or estimated weight of the item when required. This block is shown on sheet one only.

Block L Sheet number. Enter the appropriate sheet number beginning with the numeral 1. The drawing shall be prepared initially using consecutive whole numbers. When all sheets are maintained at the same revision level, sheet one shall indicate the total number of sheets. See para. 8. When all sheets are not maintained at the same revision level, the revision status of sheets block lists the total number of sheets and the total number of sheets is not required in this block.

6.3 Continuation Sheet Title Block

As a minimum, the continuation sheet title block shall contain the following: blocks C, H, I, J, and L. See Figs. 5-3 and 5-4.

7 REVISION HISTORY BLOCK

7.1 Location

The revision history block, as shown in Fig. 7-1, is located in the upper right corner of the drawing sheet. See Figs. 4-1 and 4-2. Space shall be reserved to extend the revision history block downward as required. When additional space for the revision history block is needed, a supplemental revision history block may be located to the left of the original revision history block. Revision history blocks may be included on continuation sheets.

7.2 Contents

The revision history block provides space for revision symbol, description, or identification of the change authorization document, date, and approvals. The headings shall be presented as shown in Fig. 7-1. The zone column may be added when zones are included in the drawing format and the design activity desires to identify locations of revisions. The width of the revision history block may be changed to provide for other columns as necessary. See ASME Y14.35M for completion requirements.

8 REVISION STATUS OF SHEETS BLOCK

A revision status of sheets block is required on sheet one of multiple-sheet drawings and records the revision status of each sheet. The revision status of sheets block is shown as a tabulation similar to those shown in Fig. 8-1.

The revision status of sheets block may be located in the area of the revision history block or the title block, or on a separate sheet for drawings in book form.

See ASME Y14.35M for completion requirements.

When all sheets of multiple-sheet drawings are maintained at the same revision level, the revision status of sheets block may be omitted. A note located near the title block shall state all sheets are maintained at the same revision level.

9 ASSOCIATED LISTS

See ASME Y14.34 for sheet sizes and formats of associated lists.

10 ADDITIONAL DATA BLOCKS

Blocks containing various types of additional data, when required, shall be added adjacent to the title block and in the same respective location on all drawing sheets.

When drawing size restricts placement of optional block(s), the block(s) may be located where space permits.

The following subparagraphs identify several commonly used blocks. Additional blocks may be added when required.

10.1 Angle of Projection Block

The angle of projection symbol will be as illustrated in ASME Y14.3. See Fig. 10-1 for an example of a third angle projection block. See Figs. 4-1 and 4-2 for its location within the title block. Optionally the symbol may be located near or adjacent to the title block in lieu of within the title block.

10.2 Dimensioning and Tolerancing Block

Information relative to dimensioning and tolerancing, such as angular and dimensional tolerances, are given in this block. See Fig. 10-1. Reference to ASME Y14.5 may be included in this block. When used, the block shall be in the title block area.

10.3 Application Block – Optional

When used, the application block shall be located adjacent to the title block. The application block includes columns such as next assembly, "NEXT ASSY," and where used, "USED ON," for drawings depicting a detail part or assembly of a component for a larger unit. See Fig. 10-2. The "NEXT ASSY" column lists drawing number(s) or part number(s) of the next higher assembly(ies) to which the item(s) applies. The "USED ON" column identifies the system or subsystem to which the item pertains. As an alternative, reference may be made to application data in a separately maintained document or database. See ASME Y14.34.

11 ADDITIONAL DRAWING NUMBER BLOCKS

11.1 Margin Drawing Number Block – Optional

Drawing number block location and orientation in format margins, as shown in Figs. 4-1 and 4-2, are at the option of the design activity. See Fig. 11-1.

11.2 Elongated Drawing Microfilm Identification Blocks – Optional

To facilitate the identification of microfilmed elongated drawing sizes, the microfilm identification blocks, Fig. 5-6, may be used and positioned at the right end of each microfilm segment as shown in Fig. 4-2. When required, the DAI shall be located adjacent to the identification block.

Fig. 4-1 Basic Sheet Size Formats, A0 Through A4 Sizes

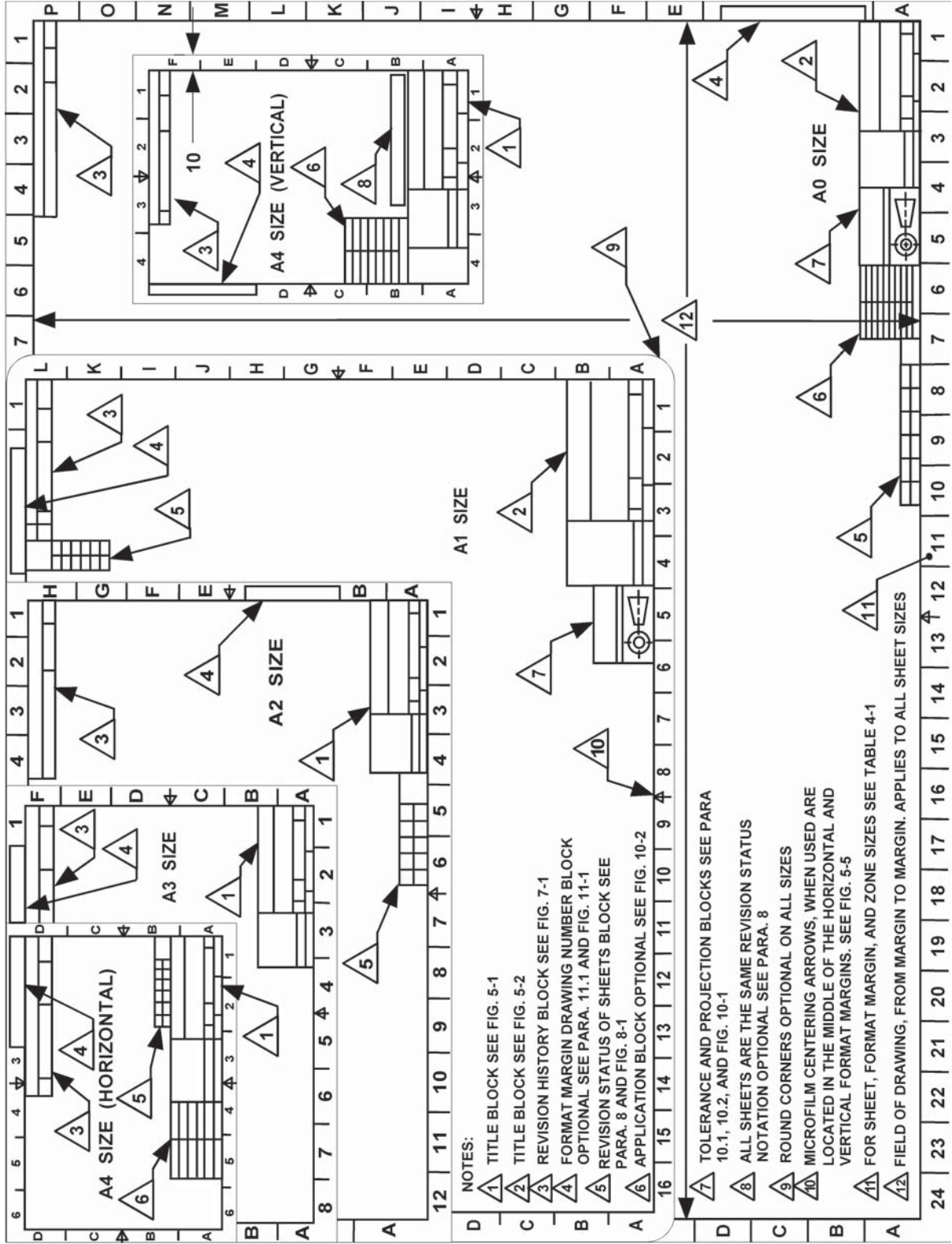
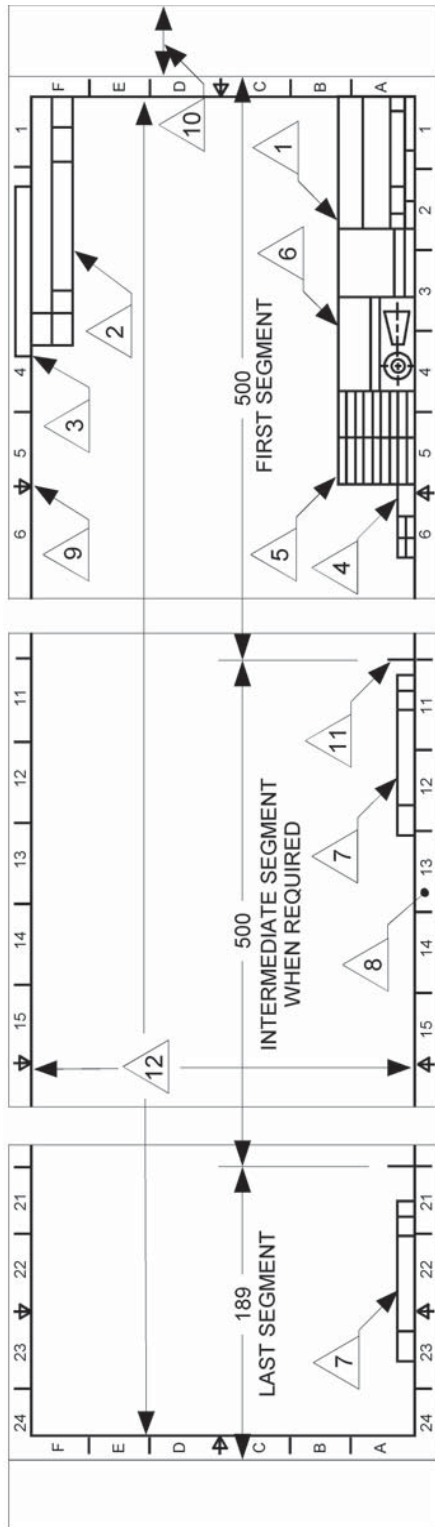

Fig. 4-2 Elongated Sheet Size Formats, A1.0, A2.1, A2.0, A3.2, A3.1, and A3.0 Sizes



NOTES:

- 1 TITLE BLOCK SEE FIG. 5-1
- 2 REVISION HISTORY BLOCK SEE FIG. 7-1
- 3 FORMAT MARGIN DRAWING NUMBER BLOCK OPTIONAL SEE PARA. 11.1 AND FIG. 11-1
- 4 REVISION STATUS OF SHEETS BLOCK SEE PARA. 8 AND FIG. 8-1
- 5 APPLICATION BLOCK OPTIONAL SEE FIG. 10-2
- 6 TOLERANCE AND PROJECTION BLOCKS SEE PARA 10.1, 10.2, AND FIG. 10-1
- 7 MICROFILM IDENTIFICATION BLOCK SEE FIG. 5-6
- 8 FOR SHEET, FORMAT MARGIN, AND ZONE SIZES SEE TABLE 4-2
- 9 MICROFILM CENTERING ARROWS, WHEN USED, ARE LOCATED IN THE HORIZONTAL FORMAT MARGINS IN THE MIDDLE OF EACH SEGMENT AND IN THE MIDDLE OF THE VERTICAL FORMAT MARGINS SEE FIG. 5-5. THIS ALLOWS FOR EITHER A RIGHT-TO-LEFT OR A LEFT-TO-RIGHT MICROFILMING PROCEDURE
- 10 PROTECTIVE MARGINS ALLOWED IN BOTH VERTICAL AND HORIZONTAL DIRECTIONS SEE PARA. 4.1.2
- 11 SEGMENT MATCH LINE (OPTIONAL)
- 12 FIELD OF DRAWING, FROM MARGIN TO MARGIN. APPLIES TO ALL SHEET SIZES

Fig. 4-3 System Size Overview

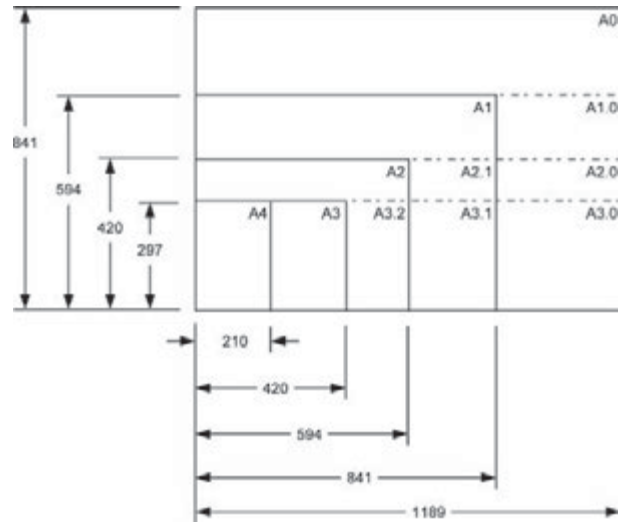
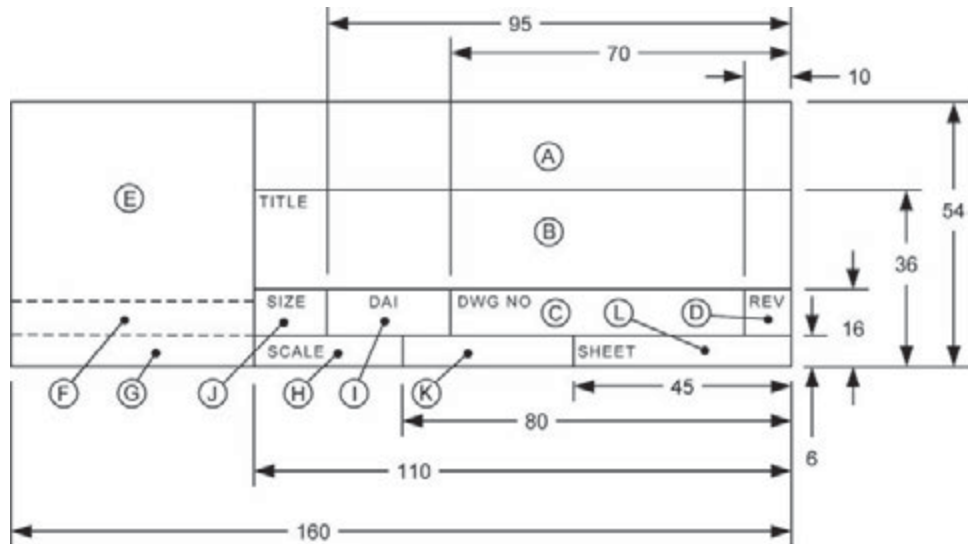
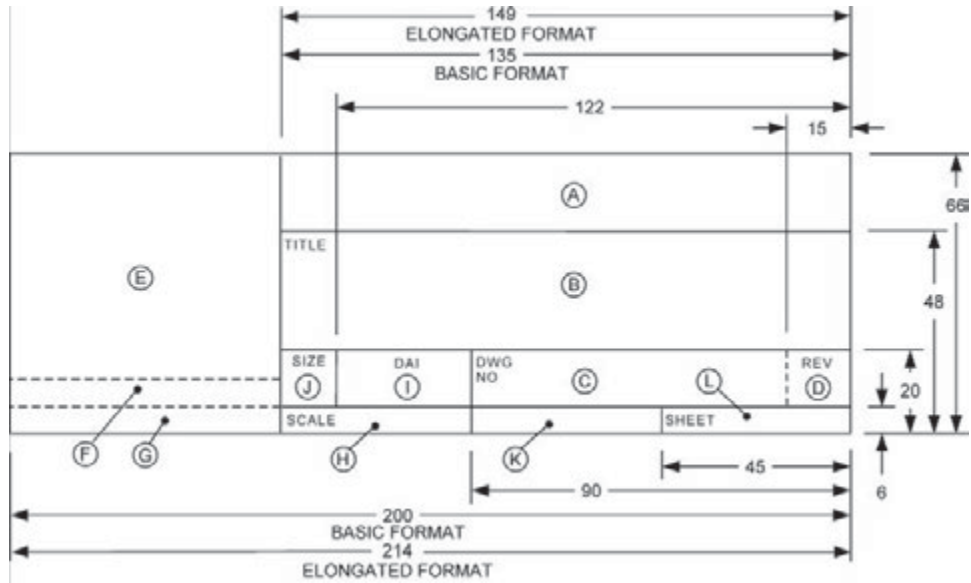

Fig. 5-1 Title Block for A2, A3, and A4 Sizes



GENERAL NOTE: See para. 6.2 for block letter references.

Fig. 5-2 Title Block for A0 and A1 Sizes



GENERAL NOTE: See para. 6.2 for block letter references.

Fig. 5-3 Continuation Sheet Title Block for A2, A3, and A4 Sizes

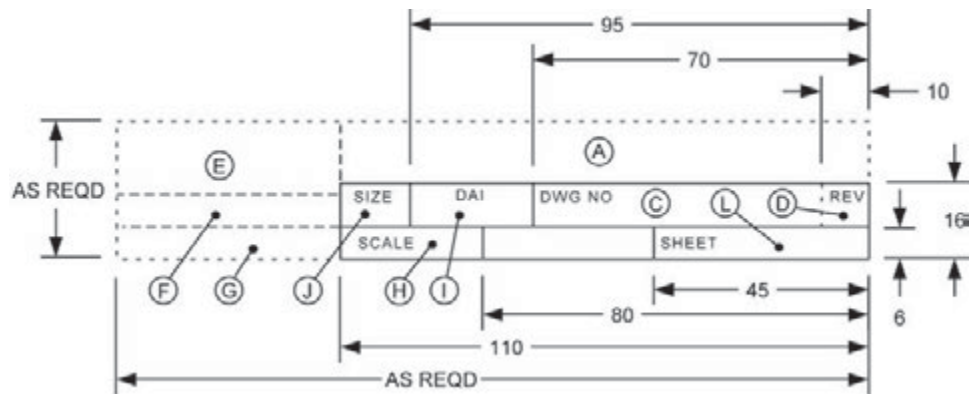

GENERAL NOTE: See para. 6.2 for block letter references.

Fig. 5-4 Continuation Sheet Title Block for A0 and A1 Sizes

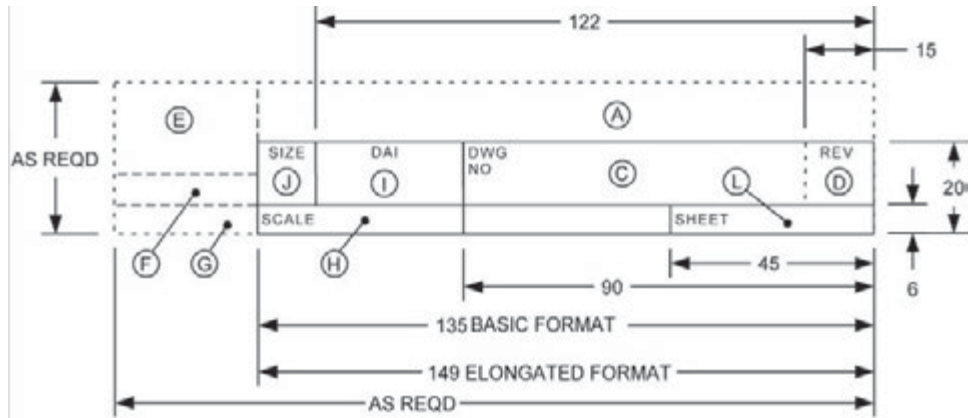

GENERAL NOTE: See para. 6.2 for block letter references.

Fig. 5-5 Microfilm Arrowheads

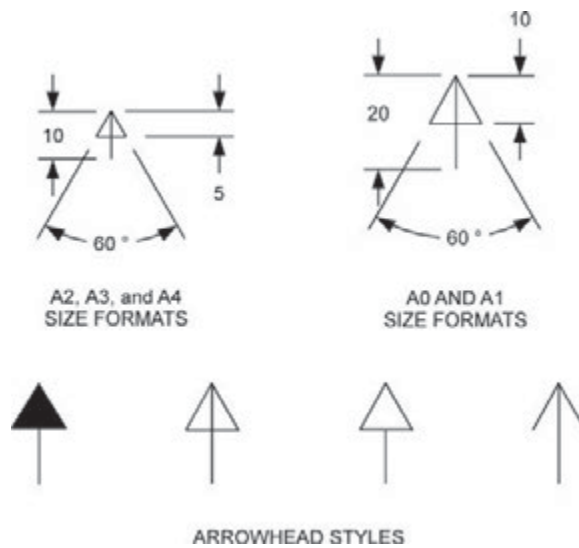

Fig. 5-6 Microfilm Identification Block

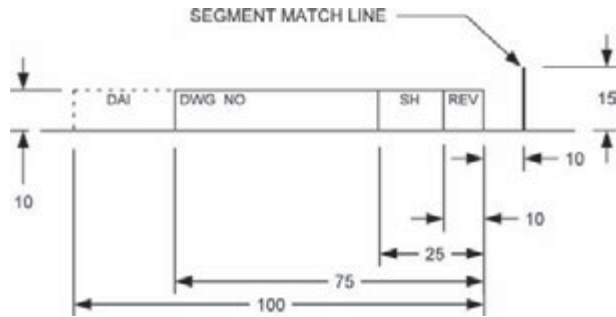

Fig. 7-1 Revision History Block

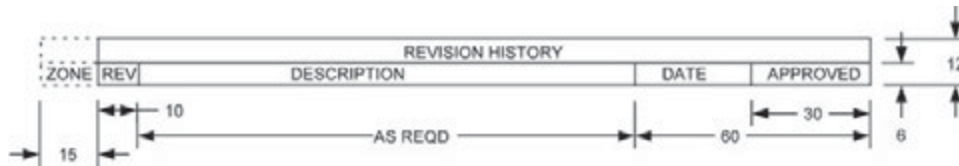

Fig. 8-1 Revision of Status of Sheets Block

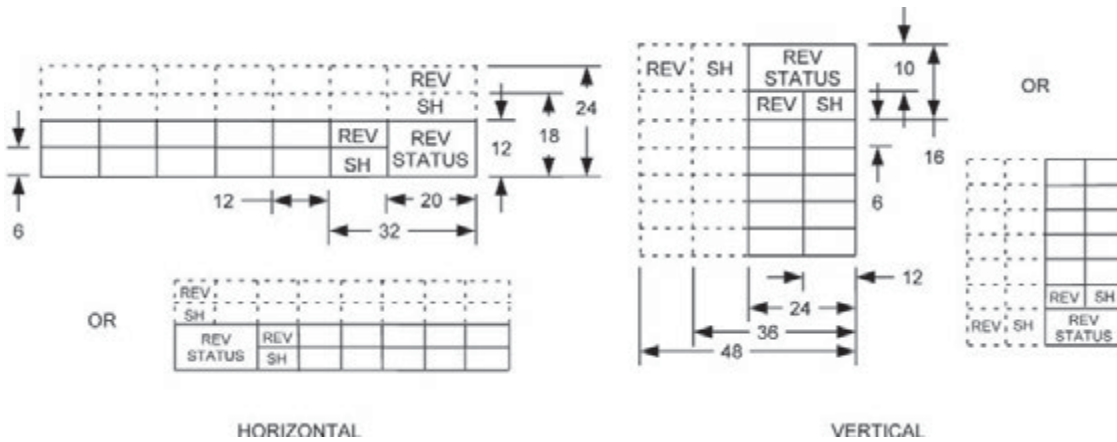

Fig. 10-1 Tolerance and Projection Blocks

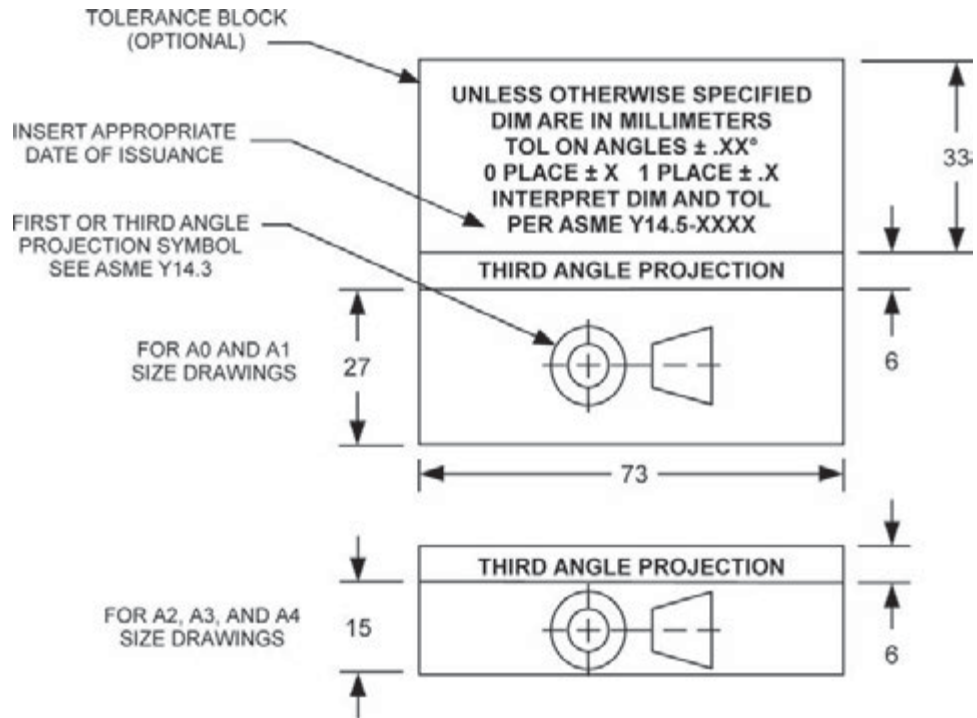

Fig. 10-2 Application Block

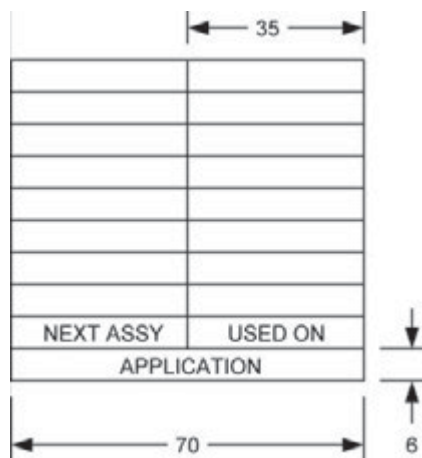

Fig. 11-1 Margin Drawing Number Block



Table 4-1 Basic Sheet Sizes

Designation	Zones [Note (1)]						Format Margin [Note (2)]		Microfilm Reduction
	Vertical	Number	Size	Horizontal	Number	Size	Vertical	Horizontal	
A0	841	16	50	1,189	24	50	20	20	30X
A1	594	12	50	841	16	50	20	20	24X
A2	420	8	50	594	12	50	10	10	16X
A3	297	6	50	420	8	50	10	10	16X
A4	297	6	50	210	4	50	10	10	16X

GENERAL NOTE: See Fig. 4-1.

NOTES:

- (1) The zone size selected shall be equal on the horizontal and the vertical, except that the upper and far left zones may be an odd size to accommodate the remaining sheet size.
- (2) Format margins do not include added protective or binding margins. See paras. 4.1.2 and 4.1.3.

Table 4-2 Elongated Sheet Sizes

Designation	Zones [Note (1)]						Format Margin [Note (2)]		Microfilm Reduction
	Vertical	Number	Size	Horizontal	Number	Size	Vertical	Horizontal	
A1.0	594	12	50	1,189	24	50	20	20	24X
A2.1	420	8	50	841	16	50	10	10	16X
A2.0	420	8	50	1,189	24	50	10	10	16X
A3.2	297	6	50	594	12	50	10	10	16X
A3.1	297	6	50	841	16	50	10	10	16X
A3.0	297	6	50	1,189	24	50	10	10	16X

GENERAL NOTE: See Fig. 4-2.

NOTES:

- (1) The zone size selected shall be equal on the horizontal and the vertical, except that the upper and far left zones may be an odd size to accommodate the remaining sheet size.
- (2) Format margins do not include added protective or binding margins. See paras. 4.1.2 and 4.1.3.

INTENTIONALLY LEFT BLANK

Y14 ENGINEERING DRAWING AND RELATED DOCUMENTATION PRACTICES

Decimal Inch Drawing Sheet Size and Format	Y14.1-2012
Metric Drawing Sheet Size and Format	Y14.1M-2012
Line Conventions and Lettering	Y14.2-2008
Multiview and Sectional View Drawings.	Y14.3-2003 (R2008)
Pictorial Drawing	Y14.4M-1989 (R2009)
Dimensioning and Tolerancing	Y14.5-2009
Mathematical Definition of Dimensioning and Tolerancing Principles	Y14.5.1M-1994 (R2004)
Certification of Geometric Dimensioning and Tolerancing Professionals	Y14.5.2-2000
Screw Thread Representation	Y14.6-2001 (R2007)
Gear Drawing Standards — Part 1 for Spur, Helical, Double Helical and Rack	Y14.7.1-1971 (R2003)
Gear and Spline Drawing Standards Part 2 — Bevel and Hypoid Gears	Y14.7.2-1978 (R2004)
Castings, Forgings, and Molded Parts	Y14.8-2009
Mechanical Spring Representation	Y14.13M-1981 (R2003)
Optical Parts	Y14.18M-1986 (R2003)
Types and Applications of Engineering Drawings	Y14.24-1999 (R2009)
Undimensioned Drawings	Y14.31-2008
Associated Lists.	Y14.34-2008
Revision of Engineering Drawings and Associated Documents.	Y14.35M-1997 (R2008)
Surface Texture Symbols	Y14.36M-1996 (R2008)
Composite Part Drawings	Y14.37-2012
Abbreviations and Acronyms for Use on Drawings and Related Documents	Y14.38-2007
Digital Product Definition Data Practices	Y14.41-2012
Digital Approval Systems	Y14.42-2002 (R2008)
Dimensioning and Tolerancing Principles for Gages and Fixtures	Y14.43-2011
Reference Designations for Electrical and Electronics Parts and Equipment	Y14.44-2008
Engineering Drawing Practices	Y14.100-2004 (R2009)
Graphic Symbols for Plumbing Fixtures for Diagrams Used in Architecture and Building Construction.	Y32.4-1977 (R2004)
Graphic Symbols for Railroad Maps and Profiles	Y32.7-1972 (R2009)
Mechanical and Acoustical Elements as Used in Schematic Diagrams	Y32.18-1972 (R2008)

The ASME Publications Catalog shows a complete list of all the Standards published by the Society. For a complimentary catalog, or the latest information about our publications, call 1-800-THE-ASME (1-800-843-2763).

ASME Services

ASME is committed to developing and delivering technical information. At ASME's Customer Care, we make every effort to answer your questions and expedite your orders. Our representatives are ready to assist you in the following areas:

ASME Press
Codes & Standards
Credit Card Orders
IMEchE Publications
Meetings & Conferences
Member Dues Status

Member Services & Benefits
Other ASME Programs
Payment Inquiries
Professional Development
Short Courses
Publications

Public Information
Self-Study Courses
Shipping Information
Subscriptions/Journals/Magazines
Symposia Volumes
Technical Papers

How can you reach us? It's easier than ever!

There are four options for making inquiries* or placing orders. Simply mail, phone, fax, or E-mail us and a Customer Care representative will handle your request.

Mail
ASME
22 Law Drive, Box 2900
Fairfield, New Jersey
07007-2900

Call Toll Free
US & Canada: 800-THE-ASME
(800-843-2763)
Mexico: 95-800-THE-ASME
(95-800-843-2763)
Universal: 973-882-1167

Fax—24 hours
973-882-1717
973-882-5155

E-Mail—24 hours
customercare@asme.org

* Customer Care staff are not permitted to answer inquiries about the technical content of this code or standard. Information as to whether or not technical inquiries are issued to this code or standard is shown on the copyright page. All technical inquiries must be submitted in writing to the staff secretary. Additional procedures for inquiries may be listed within.

INTENTIONALLY LEFT BLANK

ASME Y14.1M-2012

ISBN 978-0-7918-3486-2



9 780791 834862



N12912