

ASME B16.22-2012

[Revision of ASME B16.22-2001 (R2010)]

Wrought Copper and Copper Alloy Solder-Joint Pressure Fittings

AN AMERICAN NATIONAL STANDARD



**The American Society of
Mechanical Engineers**

INTENTIONALLY LEFT BLANK

ASME B16.22-2012

[Revision of ASME B16.22-2001 (R2010)]

Wrought Copper and Copper Alloy Solder-Joint Pressure Fittings

AN AMERICAN NATIONAL STANDARD



**The American Society of
Mechanical Engineers**

Three Park Avenue • New York, NY • 10016 USA

Date of Issuance: November 27, 2012

The next edition of this Standard is scheduled for publication in 2017.

ASME issues written replies to inquiries concerning interpretations of technical aspects of this Standard. Interpretations are published on the ASME Web site under the Committee Pages at <http://cstools.asme.org/> as they are issued.

Errata to codes and standards may be posted on the ASME Web site under the Committee Pages to provide corrections to incorrectly published items, or to correct typographical or grammatical errors in codes and standards. Such errata shall be used on the date posted.

The Committee Pages can be found at <http://cstools.asme.org/>. There is an option available to automatically receive an e-mail notification when errata are posted to a particular code or standard. This option can be found on the appropriate Committee Page after selecting “Errata” in the “Publication Information” section.

ASME is the registered trademark of The American Society of Mechanical Engineers.

This code or standard was developed under procedures accredited as meeting the criteria for American National Standards. The Standards Committee that approved the code or standard was balanced to assure that individuals from competent and concerned interests have had an opportunity to participate. The proposed code or standard was made available for public review and comment that provides an opportunity for additional public input from industry, academia, regulatory agencies, and the public-at-large.

ASME does not “approve,” “rate,” or “endorse” any item, construction, proprietary device, or activity.

ASME does not take any position with respect to the validity of any patent rights asserted in connection with any items mentioned in this document, and does not undertake to insure anyone utilizing a standard against liability for infringement of any applicable letters patent, nor assumes any such liability. Users of a code or standard are expressly advised that determination of the validity of any such patent rights, and the risk of infringement of such rights, is entirely their own responsibility.

Participation by federal agency representative(s) or person(s) affiliated with industry is not to be interpreted as government or industry endorsement of this code or standard.

ASME accepts responsibility for only those interpretations of this document issued in accordance with the established ASME procedures and policies, which precludes the issuance of interpretations by individuals.

No part of this document may be reproduced in any form,
in an electronic retrieval system or otherwise,
without the prior written permission of the publisher.

The American Society of Mechanical Engineers
Three Park Avenue, New York, NY 10016-5990

Copyright © 2012 by
THE AMERICAN SOCIETY OF MECHANICAL ENGINEERS
All Rights Reserved
Printed in U.S.A.

CONTENTS

Foreword	iv
Committee Roster	v
Summary of Changes	vi
1 Scope	1
2 General	1
3 Pressure–Temperature Ratings	1
4 Terminology	1
5 Marking	3
6 Material	3
7 Laying Lengths	3
8 Tube Stops	3
9 Inspection Tolerance	6
10 Threaded Ends	6
11 Alignment	7
12 Gaging	7
Figures	
1 Method of Designating Laying Lengths of Fittings and Openings of Reducing Fittings	4
2 Tube Stops	6
3 Alignment	7
Tables	
1 Dimensions of Solder-Joint Ends, mm	2
2 Internal Pressure–Temperature Ratings for Copper Fittings, kPa	3
3 Inspection Tolerance	6
Mandatory Appendices	
I Strength of Solder Joints	9
II U.S. Customary Equivalents	10
III References	14
Nonmandatory Appendices	
A Fitting Rating	15
B Quality System Program	16

FOREWORD

Standardization of cast and wrought solder-joint fittings was initiated in Subcommittee 11 of American Standards Association (ASA) Sectional Committee A40 on Plumbing Requirements and Equipment. Development work culminated in the publication of ASA A40.3-1941. The standard benefited from work done by A. R. Maupin of the National Bureau of Standards, both before and during its development, on the strength of solder joints.

In 1949, work on these fittings was transferred to Sectional Committee B16, which established Subcommittee 9 (now Subcommittee J) with a scope broader than plumbing applications. The first standard developed was approved as ASA B16.18-1950, Cast-Brass Solder Joint Fittings. It was then decided to revise A40.3 as a B16 standard covering only wrought solder-joint fittings. This effort was facilitated by a 1950 draft prepared by joint effort of the Copper and Brass Research Association and the Manufacturers Standardization Society of the Valve and Fittings Industry (MSS). The draft, after review and approval by Subcommittee 9 and the Sectional Committee, was approved as B16.22-1951.

Revisions were published as ASA B16.22-1963 and, after reorganization of ASA as the American National Standards Institute (ANSI), as ANSI B16.22-1973. In these editions, updated practices, new materials, and new types of fittings were incorporated into the standard, as well as editorial improvements and updating of referenced specifications and standards.

In 1979, Subcommittee I (formerly 9, now J) added metric dimensional equivalents and made other minor improvements. This revision was approved by ANSI, after approval by the Committee and secretariat organizations, as ANSI B16.22-1980.

In 1982, American National Standards Committee B16 was reorganized as an ASME Committee operating under procedures accredited by ANSI.

In 1989, Subcommittee J removed metric equivalents and updated referenced standards.

In 1995, Subcommittee J defined bursting strength, defined standard gaging method for threaded ends, revised solder-joint lengths for $\frac{1}{8}$ -in. size external and internal ends, and revised minimum wall-thickness values based on a comprehensive bursting-test study. Following approval by the Standards Committee and ASME, approval as an American National Standard was given by ANSI on July 24, 1995, with the new designation ASME B16.22-1995.

In 1998, editorial revisions, which included the addition of a new section on quality systems and a change in the designation of ASTM B32 alloys, were issued as an addendum. This addendum to the 1995 Edition of ASME B16.22, after approval by the ASME B16 Committee and ASME, was approved as ASME B16.22a-1998.

In the 2001 Edition, Subcommittee J converted the physical requirements to SI (metric) units of measure, added requirements for tube stops, clarified ovalate and alignment requirements, and made numerous editorial revisions. Alloy E and Alloy HB were incorporated into the table listing pressure-temperature ratings for the soldering and brazing materials, plus values for the 95-5 tin-antimony solder were revised. These revisions to pressure-temperature ratings reflected the data from a National Institute of Standards and Technology (NIST) solder-joint testing study, initiated in 1993 to develop stress rupture and strength data on copper tube sleeve joints using various solders. Following approval by the ASME B16 Standards Committee, approval as an American National Standard was given by ANSI on October 11, 2001, with the new designation ASME B16.22-2001.

In this 2012 Edition, the phrase “pressure-temperature ratings” replaced “working pressure” throughout the text. Following approval by the ASME B16 Standards Committee, approval as an American National Standard was given by ANSI on October 22, 2012, with the new designation ASME B16.22-2012.

Requests for interpretations or suggestions for revisions should be sent to the Secretary, B16 Committee, The American Society of Mechanical Engineers, Three Park Avenue, New York, NY 10016-5990.

ASME B16 COMMITTEE

Standardization of Valves, Flanges, Fittings, and Gaskets

(The following is the roster of the Committee at the time of approval of this Standard.)

STANDARDS COMMITTEE OFFICERS

W. B. Bedesem, *Chair*
G. A. Jolly, *Vice Chair*
D. R. Sharp, *Secretary*

STANDARDS COMMITTEE PERSONNEL

A. Appleton , Alloy Stainless Products Co., Inc.	G. A. Jolly , Vogt Valves/Flowserve Corp.
R. W. Barnes , Anric Enterprises, Inc.	M. Katcher , Haynes International
W. B. Bedesem , Consultant	W. N. McLean , B&L Engineering
R. M. Bojarczuk , ExxonMobil Research & Engineering Co.	T. A. McMahon , Emerson Process Management
D. F. Buccicone , Consultant	M. L. Nayyar , Bechtel Power Corp.
A. M. Cheta , Shell Exploration and Production Co.	W. H. Patrick , The Dow Chemical Co.
M. A. Clark , Nibco, Inc.	R. A. Schmidt , Canadoil
G. A. Cuccio , Capitol Manufacturing Co.	D. R. Sharp , The American Society of Mechanical Engineers
C. E. Davila , Crane Energy	H. R. Sonderegger , Fluoroseal, Inc.
D. R. Frikken , Becht Engineering Co.	W. M. Stephan , Flexitallic LP
R. P. Griffiths , U.S. Coast Guard	F. R. Volgstadt , Volgstadt & Associates, Inc.
	D. A. Williams , Southern Co. Generation

SUBCOMMITTEE J — COPPER AND COPPER ALLOY FLANGES

M. A. Clark , <i>Chair</i> , Nibco, Inc.	M. Gillespie , Viega North America
D. F. Buccicone , <i>Vice Chair</i> , Consultant	T. L. Jamison , Jamison Engineering
C. E. O'Brien , <i>Secretary</i> , The American Society of Mechanical Engineers	A. G. Kireta, Jr. , Copper Development Association, Inc.
J. A. Ballanco , JB Engineering & Code Consulting	A. A. Knapp , A. Knapp & Associates
S. L. Cavanaugh , Cavanaugh Consulting	C. A. Stout , Mueller Industries, Inc.
A. Ciechanowski , NSF International	R. M. McKenzie , <i>Alternate</i> , Mueller Fittings Co., Inc.
D. R. Frikken , Becht Engineering Co.	C. Mueller , <i>Alternate</i> , Mueller Industries, Inc.

ASME B16.22-2012

SUMMARY OF CHANGES

Following approval by the ASME B16 Committee and ASME, and after public review, ASME B16.22-2012 was approved by the American National Standards Institute on October 22, 2012.

ASME B16.22-2012 includes the following changes identified by a margin note, (12). In addition, in the main text, portions of section 1 were moved to section 2, and subsequent sections and their paragraphs were renumbered accordingly. All paragraph references were then revised as needed.

<i>Page</i>	<i>Location</i>	<i>Change</i>
1	3	Revised in its entirety
	4.1	Added and subsequent paragraphs redesignated
3	Table 2	(1) Title and General Notes revised (2) Under 93°C, entries revised
6	9	(1) Former para. 1.2 revised and redesignated as para. 9.1 (2) Subsequent paragraphs redesignated
9	Table I-1	Column heads and General Note revised
12	Table II-2	Title and General Notes revised
13	Table II-4	Column heads and General Note revised
14	Mandatory Appendix III	Updated
15	Nonmandatory Appendix A	Revised
16	Nonmandatory Appendix B	Revised

WROUGHT COPPER AND COPPER ALLOY SOLDER-JOINT PRESSURE FITTINGS

1 SCOPE

This Standard establishes specifications for wrought copper and wrought copper alloy, solder-joint, seamless fittings, designed for use with seamless copper tube conforming to ASTM B88 (water and general plumbing systems), B280 (air conditioning and refrigeration service), and B819 (medical gas systems), as well as fittings intended to be assembled with soldering materials conforming to ASTM B32, brazing materials conforming to AWS A5.8, or with tapered pipe thread conforming to ASME B1.20.1.

This Standard is allied with ASME B16.18, which covers cast copper alloy pressure fittings. It provides requirements for fitting ends suitable for soldering. This Standard covers the following:

- (a) pressure-temperature ratings
- (b) abbreviations for end connections
- (c) size and method of designating openings of fittings
- (d) marking
- (e) material
- (f) dimensions and tolerances
- (g) tests

2 GENERAL

2.1 Units of Measure

The values stated in either SI (metric) or U.S. Customary (in.-lb) units of measure shall be regarded separately as standard. Within the main text, SI units are given. For convenience, the customary units are shown in Mandatory Appendix II. The values stated in each system are not exact equivalents; therefore, each system shall be used independently of the other.

NOTE: Combining values from the two systems may result in nonconformance with the Standard.

2.2 References

Standards and specifications adopted by reference in this Standard are shown in Mandatory Appendix III. It is not considered practical to identify the specific edition of each standard and specification in the individual references. Instead, the specific edition reference is identified in Mandatory Appendix III.

2.3 Quality Systems

Requirements relating to the product manufacturer's quality system program are described in Nonmandatory Appendix B.

3 PRESSURE-TEMPERATURE RATINGS (12)

3.1 Rating of Fittings and Joints

The internal pressure-temperature rating for a solder-joint system is dependent upon not only fitting and tube strength, but also composition of the solder used for the joint and selection of valves and appurtenances.

3.1.1 Solder Joints. Pressure-temperature ratings for solder joints to the dimensions of Table 1 (Table II-1), made with typical commercial solders, are given in Table I-1 (Table II-4).

The internal pressure-temperature rating of the system with solder joints shall be the lowest of the values shown in Table 2 (Table II-2) and Table I-1 (Table II-4) and those of the tube, valves, and appurtenances.

3.1.2 Braze Joints. Pressure-temperature ratings for braze joints to the dimensions of Table 1 (Table II-1), made with typical commercial brazing materials, shall be considered equal to the values given in Table 2 (Table II-2).

The internal pressure-temperature rating of the system with braze joints shall be the lowest of the values shown in Table 2 (Table II-2) and those of the tube, valves, and appurtenances.

3.2 Bursting Strength

Fittings manufactured to the Standard shall have an ambient temperature bursting strength of at least four times the 38°C (100°F) internal pressure rating as shown in Table 2 (Table II-2).

4 TERMINOLOGY

4.1 Size (12)

The size of the fittings shown in Table 1 (Table II-1) corresponds to standard water tube size as shown in ASTM B88. The size of the threaded ends corresponds to nominal pipe size as shown in ASME B1.20.1.

Fittings are designated by the size of the openings in the sequence illustrated in Fig. 1.

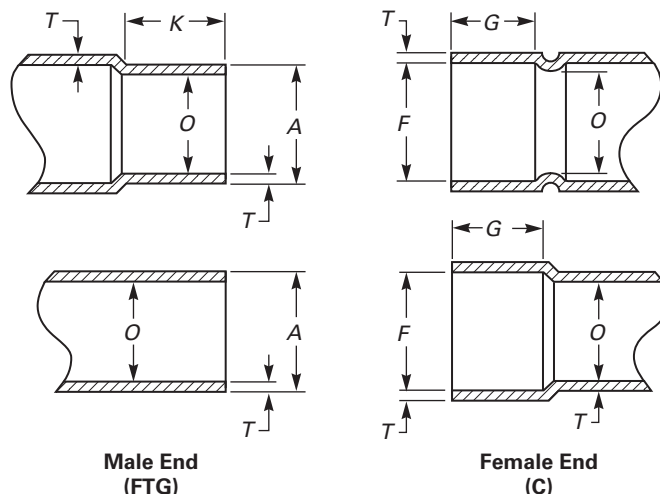
Table 1 Dimensions of Solder-Joint Ends, mm

Standard Water Tube Size [Note (1)]	External End		Internal End				Inside Diameter of Fitting, O		
	Outside Diameter, A		Length, K		Inside Diameter, F		Min. Wall Thickness, T	Dia., Min.	Out-of- Roundness, Max.
	Min.	Max. [Note (2)]	Min. [Note (3)]	Max. [Note (2)]	Min.	Max. [Note (2)]			
$\frac{1}{8}$ [Note (5)]	6.30	6.38	7.9	6.40	6.50	6.4	0.48	4.6	0.5
$\frac{1}{4}$	9.47	9.55	9.7	9.58	9.68	7.9	0.58	7.6	0.8
$\frac{3}{8}$	12.62	12.73	11.2	12.75	12.85	9.7	0.66	9.9	1.0
$\frac{1}{2}$	15.80	15.90	14.2	15.93	16.03	12.7	0.74	13.2	1.3
$\frac{5}{8}$	18.97	19.08	17.5	19.10	19.20	15.7	0.79	16.0	1.6
$\frac{3}{4}$	22.15	22.25	20.6	22.28	22.38	19.1	0.84	18.8	1.9
1	28.50	28.63	24.6	28.65	28.75	23.1	1.02	24.9	2.5
$1\frac{1}{4}$	34.85	34.98	26.2	35.00	35.10	24.6	1.12	31.2	3.1
$1\frac{1}{2}$	41.17	41.33	29.5	41.35	41.48	27.7	1.30	37.3	3.7
2	53.87	54.03	35.8	54.05	54.18	34.0	1.50	49.3	4.9
$2\frac{1}{2}$	66.57	66.73	38.9	66.75	66.88	37.3	1.70	61.5	6.1
3	79.27	79.43	43.7	79.45	79.58	42.2	1.91	73.4	7.3
$3\frac{1}{2}$	91.97	92.13	50.0	92.15	92.28	48.5	2.18	85.6	8.6
4	104.67	104.83	56.4	104.85	104.98	54.9	2.44	97.5	9.8
5	130.07	130.23	69.1	130.25	130.38	67.6	2.82	119.4	11.9
6	155.47	155.63	81.8	155.65	155.78	78.5	3.15	145.3	14.5
8	206.22	206.43	103.9	206.45	206.58	100.8	4.39	191.8	19.2

GENERAL NOTE: Drawings and designs of fittings are illustrative only. Dimensions herein shall govern in all cases.

NOTES:

- (1) For size designation of fittings, see para. 4.1.
- (2) For ovality, see para. 9.3.
- (3) The distance from the point of tangency, at the gage I.D. to the gage line, shall be equal to the dimension shown in this column.
- (4) The distance from the point of tangency, at the gage O.D. to the gage line, shall be equal to the dimension shown in this column.
- (5) $\frac{1}{8}$ size is $\frac{1}{4}$ O.D. seamless copper tube for refrigeration service, etc., as listed in ASTM B280.

Table 2 Internal Pressure–Temperature Ratings for Copper Fittings, kPa

(12)

Standard Water Tube Size [Note (1)]	–29°C to 38°C	66°C	93°C	121°C	149°C	177°C	204°C
1/4	6 280	5 340	5 130	5 020	4 920	4 190	3 140
3/8	5 360	4 560	4 380	4 290	4 200	3 570	2 680
1/2	4 970	4 220	4 060	3 980	3 890	3 310	2 480
5/8	4 350	3 700	3 550	3 480	3 410	2 900	2 170
3/4	4 010	3 410	3 270	3 210	3 140	2 670	2 000
1	3 400	2 890	2 780	2 720	2 660	2 270	1 700
1 1/4	3 020	2 570	2 470	2 420	2 370	2 010	1 510
1 1/2	2 810	2 390	2 300	2 250	2 200	1 870	1 400
2	2 500	2 130	2 040	2 000	1 960	1 670	1 250
2 1/2	2 310	1 960	1 890	1 850	1 810	1 540	1 150
3	2 180	1 850	1 780	1 740	1 710	1 450	1 090
3 1/2	2 090	1 770	1 700	1 670	1 630	1 390	1 040
4	2 020	1 710	1 650	1 610	1 580	1 340	1 010
5	1 850	1 570	1 510	1 480	1 450	1 230	920
6	1 720	1 460	1 410	1 380	1 350	1 150	860
8	1 860	1 580	1 520	1 490	1 460	1 240	930

GENERAL NOTES:

- (a) The fitting pressure–temperature rating applies to the largest opening of the fitting.
 (b) The fitting pressure–temperature rating is calculated as shown in Nonmandatory Appendix A, then rounded down to the nearest unit of 10.

NOTE:

- (1) For size designation of fittings, see para. 4.1.

4.2 Abbreviations

The following symbols are used to designate the type of fitting end:

- C = solder-joint fitting end made to receive copper tube diameter (female)
 F = internal ANSI standard taper pipe-thread end (female) NPTI
 FTG = solder-joint fitting end made to copper tube diameter (male)
 M = external ANSI standard taper pipe-thread end (male) NPTE

4.3 Definitions

out-of-roundness: maximum measured diameter minus minimum measured diameter.

ovality: elliptical condition associated with out-of-roundness.

5 MARKING

Each fitting shall be permanently marked with the manufacturer's name or trademark in accordance with MSS SP-25. Marking on fittings less than size 1/2 or on any fitting where it damages soldering surfaces is not required.

6 MATERIAL

(a) Fittings shall be made from copper UNS Nos. C10200, C12000, or C12200 or copper alloy UNS No. C23000, for which allowable stresses are found in ASME B31.1, ASME B31.9, or ASME Boiler and Pressure Vessel Code, Section II — Materials.

(b) Other coppers and copper alloys are permitted, provided they meet the chemical requirements of 84% minimum copper and 16% maximum zinc and provided the fittings produced from the copper alloy meet all the mechanical and corrosion-resistant properties for the end purposes of the fittings. The composition of the copper alloy shall contain nothing that will inhibit joining to the tube or to other fittings.

7 LAYING LENGTHS

Due to widely varying manufacturing processes, meaningful laying length requirements of fittings cannot be established. Consult the manufacturer for these dimensions.

8 TUBE STOPS

Except for repair couplings, fittings shall be manufactured with a tube stop. Repair couplings shall not require

Fig. 1 Method of Designating Laying Lengths of Fittings and Openings of Reducing Fittings

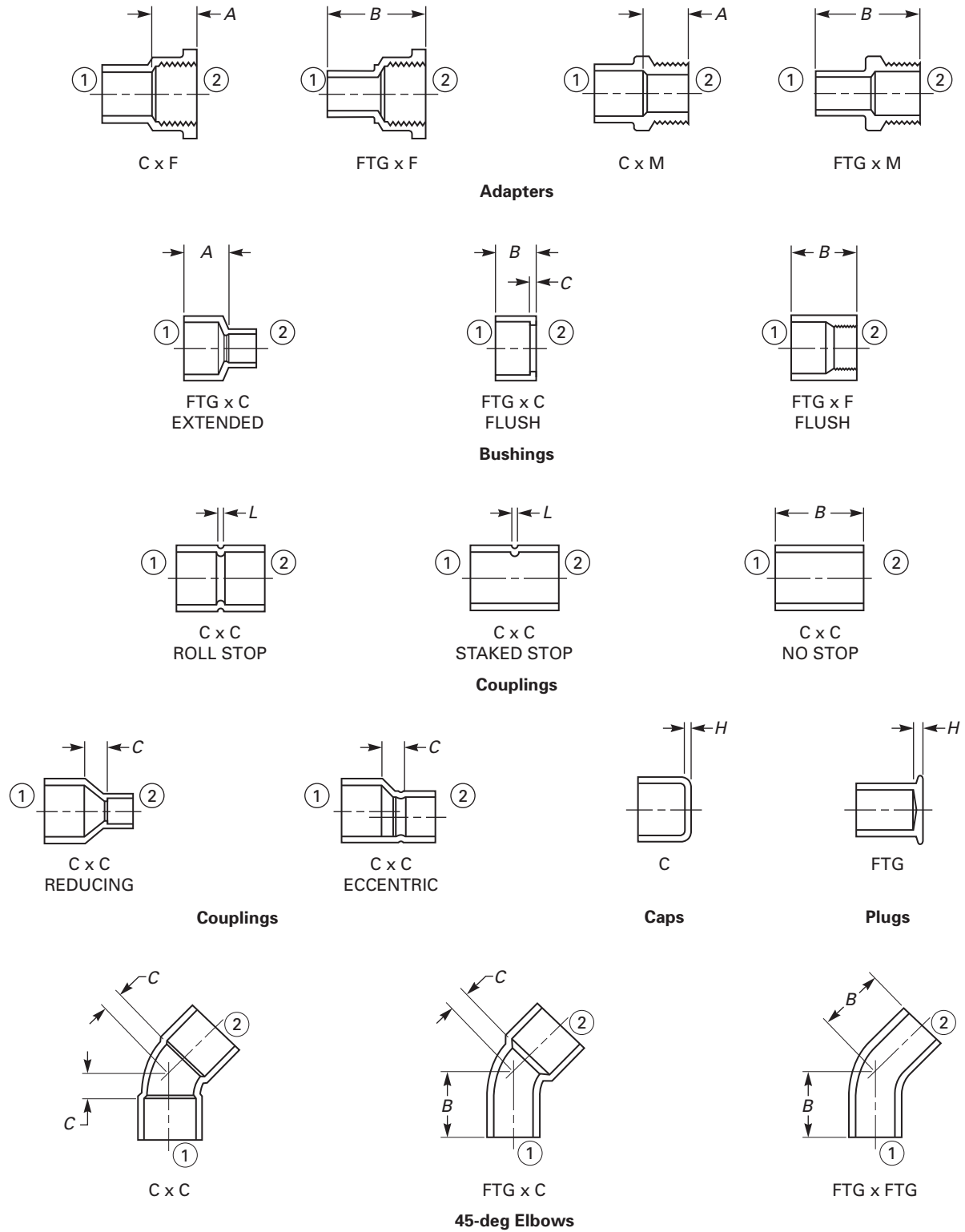
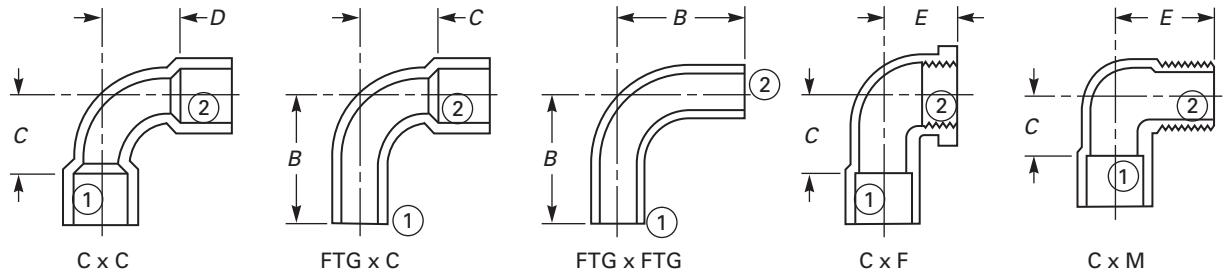
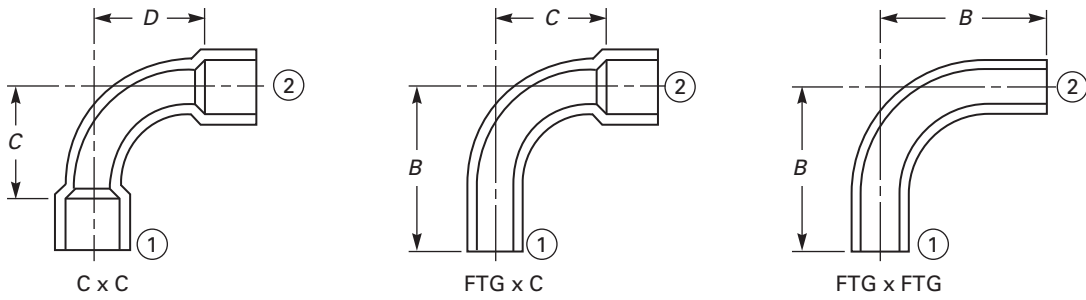

Fig. 1 Method of Designating Laying Lengths of Fittings and Openings of Reducing Fittings (Cont'd)



90-deg Elbows, Short Radius



90-deg Elbows, Long Radius

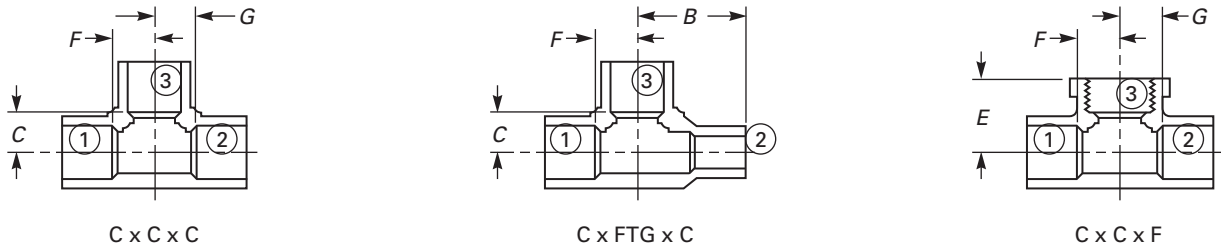

Tees

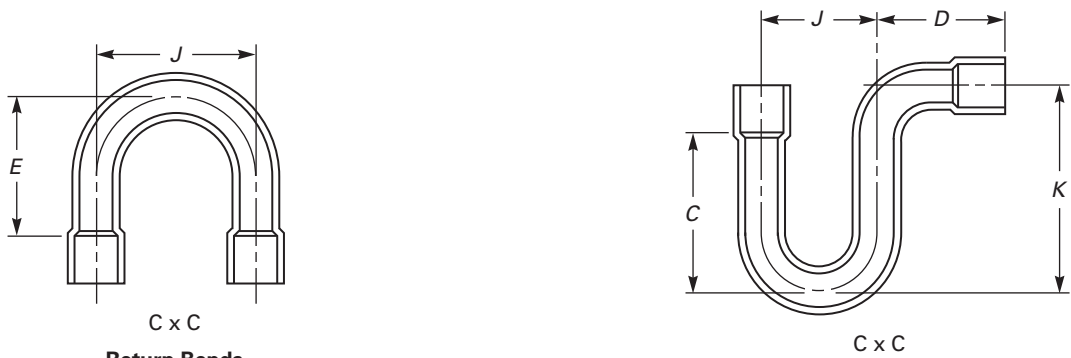

Return Bends

Suction Line P-Traps

GENERAL NOTES:

- (a) Fittings are designated by size in the order: ① × ② × ③.
- (b) Fitting designs and drawings are illustrative only.

Fig. 2 Tube Stops

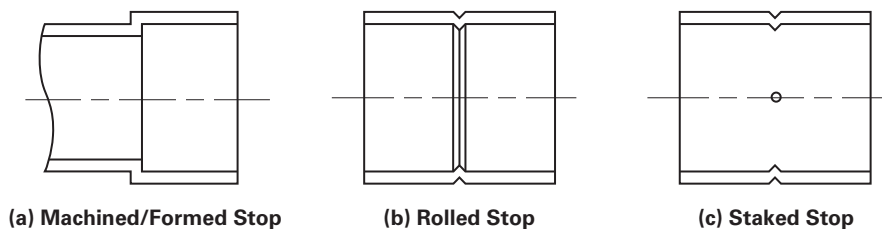

GENERAL NOTE: This figure is for illustration only; the shape and number of abutments shall be at the manufacturer's discretion.

Table 3 Inspection Tolerance

Standard Water Tube and Pipe Thread Sizes	Tolerance, mm
$\frac{1}{8}$, $\frac{1}{4}$, $\frac{3}{8}$ [Note (1)]	± 1.3
$\frac{1}{2}$, $\frac{5}{8}$, $\frac{3}{4}$	± 1.5
1, $1\frac{1}{4}$, $1\frac{1}{2}$, 2	± 2.0
$2\frac{1}{2}$, 3, $3\frac{1}{2}$	± 2.8
4 and 5	± 3.0
6 and 8	± 4.1

NOTE:

(1) $\frac{1}{8}$ size is $\frac{1}{4}$ O.D. seamless copper tube for refrigeration service, etc., as listed in ASTM B280.

a tube stop. The tube stop shall control joint length, even with an external (FTG) end having the minimum outside diameter shown in Table 1 (Table II-1). Examples of various tube stop configurations are shown in Fig. 2.

(12) 9 INSPECTION TOLERANCE

9.1 Convention

For determining conformance with this Standard, the convention for fixing significant digits where limits (maximum or minimum values) are specified shall be as defined in ASTM E29. This requires that an observed or calculated value be rounded off to the nearest unit in the last right-hand digit used for expressing the limit.

9.2 Linear Dimensions

An inspection tolerance, as shown in Table 3 (Table II-3), shall be allowed on center-to-shoulder, center-to-center, center-to-threaded-end, and shoulder-to-threaded-end dimensions on all fittings having internal (C) solder ends, as well as on center-to-solder-end and solder-end-to-threaded-end dimensions on all fittings having external (FTG) solder ends.

Coupling inspection limits for shoulder-to-shoulder and shoulder-to-end dimensions shall be double those shown in Table 3 (Table II-3), except that the minus tolerance applied to dimension L (see Fig. 1) shall not result in a dimension less than 1.5 mm (0.06 in.).

The largest opening in the fitting shall govern the tolerance to be applied to all openings.

9.3 Ovality of Fitting End (C or FTG)

Maximum ovality of the fitting solder-joint end shall not exceed 1% of the maximum diameters shown in Table 1 (Table II-1). The average of the maximum and minimum diameters shall be within the dimensions shown in the Table.

9.4 Inside Diameter of Fitting

The minimum cross-sectional area of the inside diameter through the fitting body shall not be less than the theoretical minimum area defined by diameter O in Table 1 (Table II-1). The out-of-roundness condition of the cross-sectional area shall not exceed the value shown in Table 1 (Table II-1).

For reducer or adapter fittings, the smallest end diameter shall apply, provided that this diameter does not restrict the other outlets.

9.5 Wall Thickness

The minimum wall thickness shall not be less than that shown in Table 1 (Table II-1).

10 THREADED ENDS

Fitting threads shall be right-hand, conforming to ASME B1.20.1. They shall be taper threads (NPT).

10.1 Countersink or Chamfer

All internal threads shall be countersunk a distance no less than one-half the pitch of the thread, at an angle of approximately 45 deg with the axis of the thread. All external threads shall be chamfered at an angle of 30 deg to 45 deg from the axis. Countersinking and chamfering shall be concentric with the threads.

The length of threads shall be measured to include the countersink or chamfer.

10.2 Threading Tolerances

Tapered pipe threads (NPT) shall be checked by use of plug or ring gages in either standard or limit types. When gaging internal taper threads, the plug gage shall

be screwed hand-tight into the fitting. The reference point for gaging internal product threads depends on the chamfer diameter. When the internal chamfer diameter exceeds the major diameter of the internal thread, the reference point shall be the last thread scratch on the chamfer cone. Otherwise, when the internal chamfer diameter does not exceed the major diameter of the internal thread, the reference point shall be the end of the fitting. In gaging external taper threads, the ring gage shall be screwed hand-tight on the external thread. On the external thread, the ring gage shall be flush with the end of the thread.

Tolerance for an internal threaded end having an internal shoulder shall be from the gage reference point (notch) to one turn small. Tolerance for an internally threaded end without a shoulder, and for an externally threaded end, shall be from one turn small to one turn large.

10.3 Design of Threaded Ends

The wrenching section of internally threaded ends shall be polygonal, and the wrenching section of externally threaded ends shall be furnished with either polygon or flats, at the manufacturer's option.

11 ALIGNMENT

The maximum allowable deviation in the angular alignment of any end from the specified axis position shall be $\frac{1}{2}$ deg (1 deg total). See Fig. 3.

12 GAGING

12.1 Preferred Gaging Method of Solder-Joint Ends

The preferred method of gaging the diameter tolerances for external and internal ends shall be by the use of plain plug and ring gages designed to hold the product

Fig. 3 Alignment

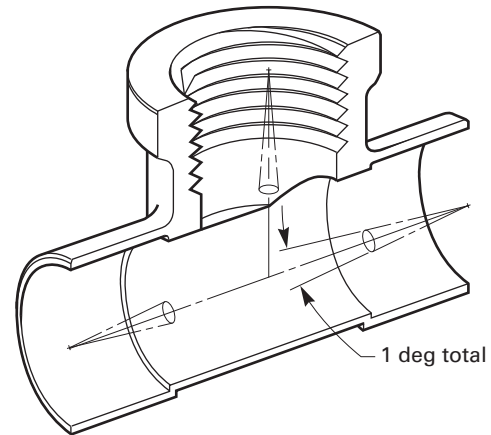

GENERAL NOTE: This figure is for illustration only.

within the limits established in Table 1 (Table II-1). Gage tolerances shall be Class ZM, as defined in ASME B4.4M.

12.2 Optional Gaging Method of Solder-Joint Ends

For gaging the diameter tolerance of external and internal ends, the use of direct reading instruments instead of ring and plug gages as specified in para. 12.1 shall be permitted. When gaging the diameters of external and internal ends using direct reading instruments, refer to para. 9.3.

12.3 Standard Gaging Method of Threaded Ends

The standard method of gaging the externally and internally threaded ends shall be in accordance with the requirements of ASME B1.20.1.

NOTE: In gaging pipe threads, it is acceptable and common practice to rap or tap the part to ensure proper seating of the gage. However, it is first necessary to clean both the gage and product threads to ensure that they are free of chips, burrs, abrasives, or other foreign materials.

INTENTIONALLY LEFT BLANK

MANDATORY APPENDIX I

STRENGTH OF SOLDER JOINTS

The maximum recommended pressure–temperature ratings for solder joints made with copper tube and wrought copper and copper alloy pressure fittings, using representative commercial solders, are listed in Table I-1. These pressure–temperature ratings are based on solder joints made in accordance with the requirements of ASTM B828.

Table I-1 Pressure–Temperature Ratings

(12)

Joining Material	Temperature, °C	Maximum Gage Pressure for Standard Water Tube Sizes, kPa [Note (1)]			
		$\frac{1}{8}$ Through 1	$1\frac{1}{4}$ Through 2	$2\frac{1}{2}$ Through 4	5 Through 8
		Alloy Sn50	38	1 375	1 205
50–50 tin–lead solder [Notes (2), (3)]	66	1 030	860	685	620
	93	685	620	515	480
	121	585	515	340	310
Alloy Sb5	38	7 540 [Note (4)]	5 880 [Note (5)]	4 880 [Note (5)]	4 555 [Note (5)]
95–5 tin–antimony solder [Note (7)]	66	4 315 [Note (6)]	3 365 [Note (6)]	2 790 [Note (6)]	2 605 [Note (6)]
	93	3 500 [Note (8)]	2 730 [Note (6)]	2 265 [Note (6)]	2 115 [Note (6)]
	121	1 885	1 475	1 220	1 135
Alloy E [Note (9)]	38	4 905 [Note (6)]	3 825 [Note (6)]	3 175 [Note (6)]	2 965 [Note (6)]
	66	3 275 [Note (8)]	2 550 [Note (6)]	2 115 [Note (6)]	1 975 [Note (8)]
	93	2 595	2 025	1 680 [Note (8)]	1 570 [Note (8)]
	121	2 230	1 735	1 440	1 340
Alloy HB [Note (10)]	38	7 135 [Note (4)]	5 560 [Note (5)]	4 615 [Note (5)]	4 305 [Note (4)]
	66	4 905 [Note (6)]	3 825 [Note (6)]	3 175 [Note (6)]	2 965 [Note (6)]
	93	3 045 [Note (8)]	2 375 [Note (8)]	1 970 [Note (8)]	1 840 [Note (8)]
	121	2 970 [Note (8)]	2 315 [Note (8)]	1 920 [Note (8)]	1 800 [Note (8)]
Joining materials melting at or above 593°C [Note (11)]		Pressure–temperature ratings consistent with the materials and procedures employed			

GENERAL NOTE: For temperatures in the –18°C to –93°C range, it is recommended that a joint material melting at or above 593°C be employed [see Note (9)].

NOTES:

- (1) Standard water tube sizes per ASTM B88.
- (2) ASTM B32 Alloy Grade Sn50.
- (3) The Safe Drinking Water Act Amendments of 1986 prohibit the use of any solder having a lead content in excess of 0.2% in potable water systems.
- (4) The solder joint exceeds the strength of Types L and M tube in drawn temper and Type K tube in annealed temper.
- (5) The solder joint exceeds the strength of Types K, L, and M tube in drawn and annealed tempers.
- (6) The solder joint exceeds the strength of Type M tube in drawn temper and Types L and K in annealed temper.
- (7) ASTM B32 Alloy Grade Sb5.
- (8) The solder joint exceeds the strength of Type L tube in annealed temper.
- (9) ASTM B32 Alloy Grade E.
- (10) ASTM B32 Alloy Grade HB.
- (11) These joining materials are defined as “brazing alloys” by the American Welding Society.

MANDATORY APPENDIX II U.S. CUSTOMARY EQUIVALENTS

See Tables II-1 through II-4.

Table II-1 Dimensions of Solder-Joint Ends, in.

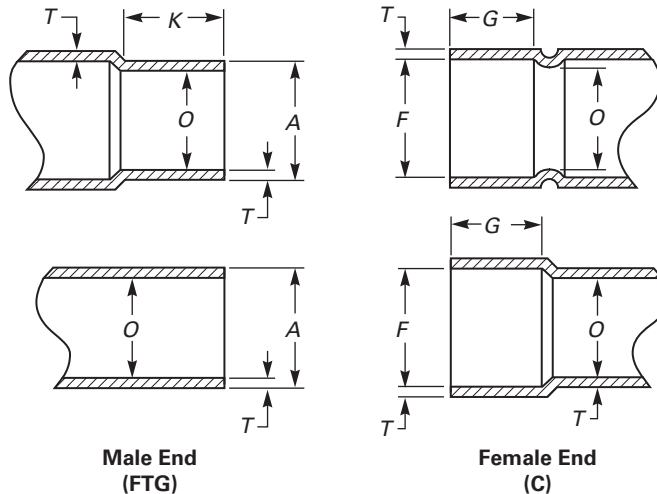

Standard Water Tube Size [Note (1)]	External End			Internal End			Inside Diameter of Fitting, <i>O</i>		
	Outside Diameter, <i>A</i>		Length, <i>K</i>	Inside Diameter, <i>F</i>		Min. Depth, <i>G</i> [Note (4)]	Min. Wall Thickness, <i>T</i>	Dia., Min.	Out-of- Roundness, Max.
	Min.	Max. [Note (2)]	Min. [Note (3)]	Min.	Max. [Note (2)]				
$\frac{1}{8}$ [Note (5)]	0.248	0.251	0.31	0.252	0.256	0.25	0.019	0.18	0.02
$\frac{1}{4}$	0.373	0.376	0.38	0.377	0.381	0.31	0.023	0.30	0.03
$\frac{3}{8}$	0.497	0.501	0.44	0.502	0.506	0.38	0.026	0.39	0.04
$\frac{1}{2}$	0.622	0.626	0.56	0.627	0.631	0.50	0.029	0.52	0.05
$\frac{5}{8}$	0.747	0.751	0.69	0.752	0.756	0.62	0.031	0.63	0.06
$\frac{3}{4}$	0.872	0.876	0.81	0.877	0.881	0.75	0.033	0.74	0.07
1	1.122	1.127	0.97	1.128	1.132	0.91	0.040	0.98	0.10
$1\frac{1}{4}$	1.372	1.377	1.03	1.378	1.382	0.97	0.044	1.23	0.12
$1\frac{1}{2}$	1.621	1.627	1.16	1.628	1.633	1.09	0.051	1.47	0.15
2	2.121	2.127	1.41	2.128	2.133	1.34	0.059	1.94	0.19
$2\frac{1}{2}$	2.621	2.627	1.53	2.628	2.633	1.47	0.067	2.42	0.24
3	3.121	3.127	1.72	3.128	3.133	1.66	0.075	2.89	0.29
$3\frac{1}{2}$	3.621	3.627	1.97	3.628	3.633	1.91	0.086	3.37	0.34
4	4.121	4.127	2.22	4.128	4.133	2.16	0.096	3.84	0.38
5	5.121	5.127	2.72	5.128	5.133	2.66	0.111	4.70	0.47
6	6.121	6.127	3.22	6.128	6.133	3.09	0.124	5.72	0.57
8	8.119	8.127	4.09	8.128	8.133	3.97	0.173	7.55	0.76

GENERAL NOTE: Drawings and designs of fittings are illustrative only. Dimensions herein shall govern in all cases.

NOTES:

- (1) For size designation of fittings, see para. 4.1.
- (2) For ovality, see para. 9.3.
- (3) The distance from the point of tangency, at the gage I.D. to the gage line, shall be equal to the dimension shown in this column.
- (4) The distance from the point of tangency, at the gage O.D. to the gage line, shall be equal to the dimension shown in this column.
- (5) $\frac{1}{8}$ size is $\frac{1}{4}$ O.D. seamless copper tube for refrigeration service, etc., as listed in ASTM B280.

(12) **Table II-2 Internal Pressure–Temperature Ratings for Copper Fittings, psi**

Standard Water Tube Size [Note (1)]	–20°F to 100°F	150°F	200°F	250°F	300°F	350°F	400°F
1/4	910	770	740	725	710	605	455
3/8	775	660	635	620	610	515	385
1/2	720	610	585	575	565	480	360
5/8	630	535	515	505	490	420	315
3/4	580	490	475	465	455	385	290
1	490	420	400	395	385	325	245
1 1/4	435	370	355	350	340	290	215
1 1/2	405	345	330	325	315	270	200
2	360	305	295	290	280	240	180
2 1/2	335	285	270	265	260	220	165
3	315	265	255	250	245	210	155
3 1/2	300	255	245	240	235	200	150
4	290	245	235	230	225	195	145
5	265	225	215	215	210	175	130
6	250	210	200	200	195	165	125
8	270	225	220	215	210	180	135

GENERAL NOTES:

- (a) The fitting pressure–temperature rating applies to the largest opening of the fitting.
 (b) The fitting pressure–temperature rating is calculated as shown in Nonmandatory Appendix A, then rounded down to the nearest unit of 5.

NOTE:

- (1) For size designation of fittings, see para. 4.1.

Table II-3 Inspection Tolerance

Standard Water Tube and Pipe Thread Sizes	Tolerance, in.
1/8, 1/4, 3/8 [Note (1)]	±0.05
1/2, 5/8, 3/4	±0.06
1, 1 1/4, 1 1/2, 2	±0.08
2 1/2, 3, 3 1/2	±0.11
4 and 5	±0.12
6 and 8	±0.16

NOTE:

- (1) 1/8 size is 1/4 O.D. seamless copper tube for refrigeration service, etc., as listed in ASTM B280.

Table II-4 Pressure–Temperature Ratings

(12)

Joining Material	Temperature, °F	Maximum Gage Pressure for Standard Water Tube Sizes, psi [Note (1)]			
		$\frac{1}{8}$ Through 1	$1\frac{1}{4}$ Through 2	$2\frac{1}{2}$ Through 4	5 Through 8
Alloy Sn50	100	200	175	150	135
50–50 tin–lead solder	150	150	125	100	90
[Notes (2), (3)]	200	100	90	75	70
	250	85	75	50	45
Alloy Sb5	100	1,090 [Note (4)]	850 [Note (5)]	705 [Note (5)]	660 [Note (5)]
95–5 tin–antimony solder	150	625 [Note (6)]	485 [Note (6)]	405 [Note (6)]	375 [Note (6)]
[Note (7)]	200	505 [Note (8)]	395 [Note (6)]	325 [Note (6)]	305 [Note (6)]
	250	270	210	175	165
Alloy E	100	710 [Note (6)]	555 [Note (6)]	460 [Note (6)]	430 [Note (6)]
[Note (9)]	150	475 [Note (8)]	370 [Note (6)]	305 [Note (6)]	285 [Note (8)]
	200	375	290	240 [Note (8)]	225 [Note (8)]
	250	320	250	205	195
Alloy HB	100	1,035 [Note (4)]	805 [Note (5)]	670 [Note (5)]	625 [Note (4)]
[Note (10)]	150	710 [Note (6)]	555 [Note (6)]	460 [Note (6)]	430 [Note (6)]
	200	440 [Note (8)]	345 [Note (8)]	285 [Note (8)]	265 [Note (8)]
	250	430 [Note (8)]	335 [Note (8)]	275 [Note (8)]	260 [Note (8)]
Joining materials melting at or above 1,100°F [Note (11)]		Pressure–temperature ratings consistent with the materials and procedures employed			

GENERAL NOTE: For temperatures in the 0°F to –200°F range, it is recommended that a joint material melting at or above 1,100°F be employed [see Note (9)].

NOTES:

- (1) Standard water tube sizes per ASTM B88.
- (2) ASTM B32 Alloy Grade Sn50.
- (3) The Safe Drinking Water Act Amendments of 1986 prohibit the use of any solder having a lead content in excess of 0.2% in potable water systems.
- (4) The solder joint exceeds the strength of Types L and M tube in drawn temper and Type K tube in annealed temper.
- (5) The solder joint exceeds the strength of Types K, L, and M tube in drawn and annealed tempers.
- (6) The solder joint exceeds the strength of Type M tube in drawn temper and Types L and K in annealed temper.
- (7) ASTM B32 Alloy Grade Sb5.
- (8) The solder joint exceeds the strength of Type L tube in annealed temper.
- (9) ASTM B32 Alloy Grade E.
- (10) ASTM B32 Alloy Grade HB.
- (11) These joining materials are defined as “brazing alloys” by the American Welding Society.

(12)

MANDATORY APPENDIX III REFERENCES

The following is a list of standards and specifications referenced in this Standard, showing the year of approval.

2010 ASME Boiler and Pressure Vessel Code, Section II, Part B — Nonferrous Material Specifications

ASME B1.20.1-1983 (R2006), Pipe Threads, General Purpose (Inch)

ASME B4.4M-1981 (R1994), Inspection of Workpieces

ASME B16.18-1984 (R2005), Cast Copper Alloy Solder Joint Pressure Fittings

ASME B31.1-2010, Power Piping

ASME B31.9-2008, Building Services Piping

Publisher: The American Society of Mechanical Engineers (ASME), Three Park Avenue, New York, NY 10016-5990; Order Department: 22 Law Drive, P.O. Box 2900, Fairfield, NJ 07007-2900 (www.asme.org)

ASTM B32-08, Specification for Solder Metal

ASTM B88-09, Specification for Seamless Copper Water Tube

ASTM B280-08, Specification for Seamless Copper Tube for Air Conditioning and Refrigeration Field Service

ASTM B819-00 (R2006), Specification for Seamless Copper Tube for Medical Gas Systems

ASTM B828-02 (R2010), Standard Practice for Making Capillary Joints by Soldering of Copper and Copper Alloy Tube and Fittings

ASTM E29-08, Practice for Using Significant Digits in Test Data to Determine Conformance with Specifications

Publisher: American Society for Testing and Materials (ASTM International), 100 Barr Harbor Drive, P.O. Box C700, West Conshohocken, PA 19428-2959 (www.astm.org)

AWS A5.8M-2004, Specification for Filler Metals for Brazing and Braze Welding¹

Publisher: American Welding Society (AWS), 550 NW Le Jeune Road, Miami, FL 33126 (www.aws.org)

ISO 9000:2005, Quality management systems — Fundamentals and vocabulary¹

ISO 9001:2008 COR 1-2009, Quality management systems — Requirements¹

ISO 9004:2009, Quality management systems — Guidelines for performance improvements¹

Publisher: International Organization for Standardization (ISO) Central Secretariat, 1, ch. de la Voie-Creuse, Case postale 56, CH-1211, Genève 20, Switzerland/Suisse (www.iso.org)

MSS SP-25-2008, Standard Marking System for Valves, Fittings, Flanges and Unions

Publisher: Manufacturers Standardization Society of the Valve and Fittings Industry, Inc. (MSS), 127 Park Street, NE, Vienna, VA 22180 (www.mss-hq.org)

¹ May also be obtained from American National Standards Institute (ANSI), 25 West 43rd Street, New York, NY 10036.

NONMANDATORY APPENDIX A FITTING RATING

(12)

The pressure–temperature ratings of the fittings are shown in Table 2 (Table I-2). These values are the same as those calculated for annealed temper ASTM B88 Type L copper water tube. The rated internal working pressures for annealed temper ASTM B88 Type L copper water tube are calculated as follows:

$$p = \frac{2St}{D - 0.8t}$$

where

D = maximum outside diameter, mm (in.), for annealed temper ASTM B88 Type L water tube

p = rated pressure at temperature, kPa (psi)

S = allowable stress at temperature, kPa (psi), from ASME B31.1 or ASME B31.9, for annealed temper ASTM B88 Type L copper water tube

t = minimum wall thickness, mm (in.), for annealed temper ASTM B88 Type L water tube

(12)

NONMANDATORY APPENDIX B QUALITY SYSTEM PROGRAM

The products manufactured in accordance with this Standard shall be produced under a quality system program following the principles of an appropriate standard from the ISO 9000 series.¹ A determination of the need for registration and/or certification of the product

¹ The series is also available from the American National Standards Institute (ANSI) and the American Society for Quality (ASQ) as American National Standards that are identified by the prefix "Q," replacing the prefix "ISO." Each standard of the series is listed under References in Mandatory Appendix III.

manufacturer's quality system program by an independent organization shall be the responsibility of the manufacturer. The detailed documentation demonstrating program compliance shall be available to the purchaser at the manufacturer's facility. A written summary description of the program utilized by the product manufacturer shall be available to the purchaser upon request. The *product manufacturer* is defined as the entity whose name, or trademark, appears on the product in accordance with the marking or identification requirements of this Standard.

B16 AMERICAN NATIONAL STANDARDS FOR PIPING, PIPE FLANGES, FITTINGS, AND VALVES

Gray Iron Pipe Flanges and Flanged Fittings (Classes 25, 125, and 250)	B16.1-2010
Malleable Iron Threaded Fittings: Classes 150 and 300	B16.3-2011
Gray Iron Threaded Fittings: Classes 125 and 250	B16.4-2011
Pipe Flanges and Flanged Fittings NPS ½ Through NPS 24 Metric/Inch Standard	B16.5-2009
Factory-Made Wrought Butt welding Fittings	B16.9-2007
Face-to-Face and End-to-End Dimensions of Valves	B16.10-2009
Forged Fittings, Socket-Welding and Threaded	B16.11-2011
Cast Iron Threaded Drainage Fittings	B16.12-2009
Ferrous Pipe Plugs, Bushings, and Locknuts with Pipe Threads	B16.14-2010
Cast Copper Alloy Threaded Fittings	B16.15-2011
Cast Copper Alloy Solder Joint Pressure Fittings	B16.18-2012
Metallic Gaskets for Pipe Flanges: Ring-Joint, Spiral-Wound, and Jacketed	B16.20-2007
Nonmetallic Flat Gaskets for Pipe Flanges	B16.21-2005
Wrought Copper and Copper Alloy Solder-Joint Pressure Fittings	B16.22-2012
Cast Copper Alloy Solder Joint Drainage Fittings: DWV	B16.23-2011
Cast Copper Alloy Pipe Flanges and Flanged Fittings: Classes 150, 300, 600, 900, 1500, and 2500	B16.24-2011
Butt welding Ends	B16.25-2007
Cast Copper Alloy Fittings for Flared Copper Tubes	B16.26-2011
Wrought Copper and Wrought Copper Alloy Solder-Joint Drainage Fittings — DWV	B16.29-2012
Manually Operated Metallic Gas Valves for Use in Gas Piping Systems Up to 125 psi (Sizes NPS ½ Through NPS 2)	B16.33-2002 (R2007)
Valves — Flanged, Threaded, and Welding End	B16.34-2004
Orifice Flanges	B16.36-2009
Large Metallic Valves for Gas Distribution: Manually Operated, NPS 2½ (DN 65) to NPS 12 (DN 300), 125 psig (8.6 bar) Maximum	B16.38-2012
Malleable Iron Threaded Pipe Unions: Classes 150, 250, and 300	B16.39-2009
Manually Operated Thermoplastic Gas Shutoffs and Valves in Gas Distribution Systems	B16.40-2008
Ductile Iron Pipe Flanges and Flanged Fittings: Classes 150 and 300	B16.42-2011
Manually Operated Metallic Gas Valves for Use in Aboveground Piping Systems Up to 5 psi	B16.44-2002 (R2007)
Cast Iron Fittings for Sovent® Drainage Systems	B16.45-1998 (R2006)
Large Diameter Steel Flanges NPS 26 Through NPS 60 Metric/Inch Standard	B16.47-2011
Line Blanks	B16.48-2010
Factory-Made Wrought Steel Butt welding Induction Bends for Transportation and Distribution Systems	B16.49-2007
Wrought Copper and Copper Alloy Braze-Joint Pressure Fittings	B16.50-2001 (R2008)
Copper and Copper Alloy Press-Connect Pressure Fittings	B16.51-2011

The ASME Publications Catalog shows a complete list of all the Standards published by the Society. For a complimentary catalog, or the latest information about our publications, call 1-800-THE-ASME (1-800-843-2763).

ASME Services

ASME is committed to developing and delivering technical information. At ASME's Customer Care, we make every effort to answer your questions and expedite your orders. Our representatives are ready to assist you in the following areas:

ASME Press
Codes & Standards
Credit Card Orders
IMEchE Publications
Meetings & Conferences
Member Dues Status

Member Services & Benefits
Other ASME Programs
Payment Inquiries
Professional Development
Short Courses
Publications

Public Information
Self-Study Courses
Shipping Information
Subscriptions/Journals/Magazines
Symposia Volumes
Technical Papers

How can you reach us? It's easier than ever!

There are four options for making inquiries* or placing orders. Simply mail, phone, fax, or E-mail us and a Customer Care representative will handle your request.

Mail
ASME
22 Law Drive, Box 2900
Fairfield, New Jersey
07007-2900

Call Toll Free
US & Canada: 800-THE-ASME
(800-843-2763)
Mexico: 95-800-THE-ASME
(95-800-843-2763)
Universal: 973-882-1167

Fax—24 hours
973-882-1717
973-882-5155

E-Mail—24 hours
customercare@asme.org

* Customer Care staff are not permitted to answer inquiries about the technical content of this code or standard. Information as to whether or not technical inquiries are issued to this code or standard is shown on the copyright page. All technical inquiries must be submitted in writing to the staff secretary. Additional procedures for inquiries may be listed within.

INTENTIONALLY LEFT BLANK

ASME B16.22-2012

ISBN 978-0-7918-3441-1



9 780791 834411



M03012